

广州锐拓仪器科技有限公司 传感事业部内部使用资料 江工  
技术参数

额定载荷 (R.C.)	kg	5, 10, 20, 30, 50, 100, 200, 300, 500
	t	1, 2, 3, 5
额定输出 (R.O.)	mV/V	2±0.0050
零点平衡	mV/V	±0.018
综合误差	%R.O.	±0.030
非线性	%R.O.	±0.030
滞后	%R.O.	±0.020
重复性	%R.O.	±0.170
蠕变 (30 分钟)	%R.O.	±0.024
正常工作温度范围	°C	-10...+40
允许工作温度范围	°C	-20...+70
温度对灵敏度影响	%R.O./10 °C	±0.02
温度对零点影响	%R.O./10 °C	±0.02
推荐激励电压	VDC	10
最大激励电压	VDC	15
输入阻抗	Ω	380±5
输出阻抗	Ω	350±3

绝缘阻抗	MΩ	>5000
安全过载	%R.C.	150
极限过载	%R.C.	300
弹性元件材料		合金钢
防护等级		IP65/ IP66
电缆线长度	m	3m(5-50kg), 5m(100kg...5t)
接线方式	激励	红: +      黑: -
	信号	绿: +      白: -

测力传感器—S型测力传感器—STC

S型测力传感器型号: STC-25kg 称重传感器

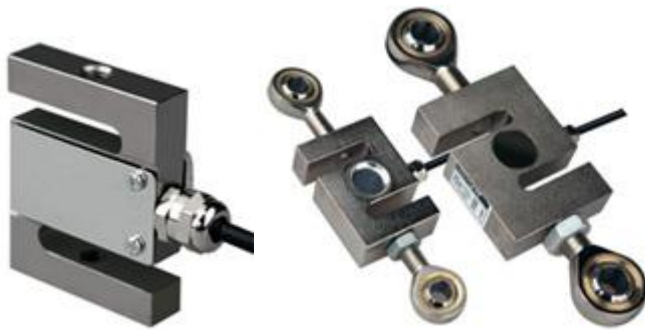

产品特点:

- 结构紧凑，安装方便
- 拉、压力均可
- 综合精度高，长期稳定性好
- 优质合金钢，表面镀镍
- 适用于吊钩秤、机电结合秤、料斗秤、料罐秤、包装秤、配料称重控制、试验机、力的监控及测量

外型尺寸:

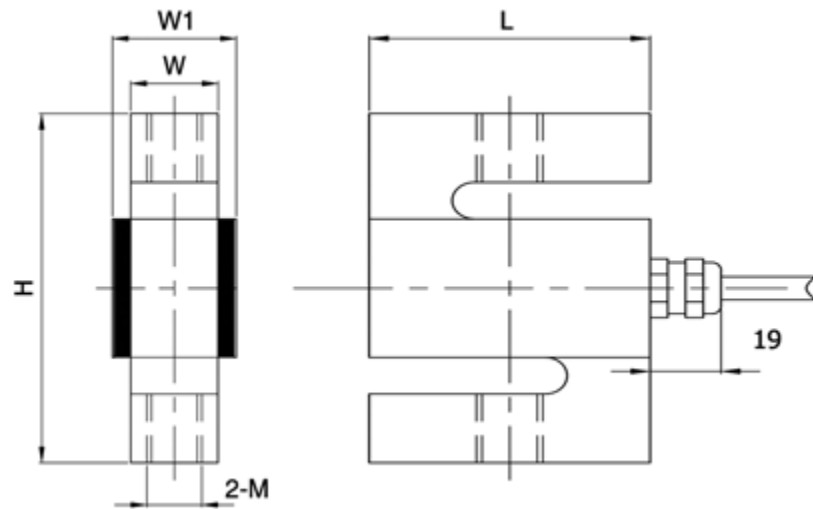

额定载荷 (kg)		L	H	W	W1	M
5, 10, 20, 30, 50	mm	50.8	63.5	12.7	20	M 8×1.25
100, 200, 300, 500	mm	50.8	76.2	19.1	27	M 12×1.75
1000, 1500	mm	50.8	76.2	25.4	33	M 12×1.75
2000, 3000, 5000	mm	76.2	107.9	25.4	33	M 18×1.5



STC-25kg 称重传感器

#### FEATURES

Capacities: 25 to 5Kkg, 250 to 40Klb

Alloy steel construction

Stainless steel available

Bi-direction (tension/compression)

Rationalized output

NTEP Class III 5000S, ILL10000 approval from 250lb to 20Klb

#### **OPTIONAL FEATURE**

FM approval available

#### **DESCRIPTION**

S Type load cell as the name indicated can be easily identified by S-shaped body. They can be loaded either in tension or compression, and used for single or multiple- cell application if the output is rationalized. STC is made of alloy or stainless steel, sealed to IP67 providing excellent protection against moisture and humidity.

#### **APPLICATIONS STC-25kg 称重传感器**

Electro-mechanical conversion scales

Silo / hopper / tank weighing

Crane scales

Fork-lift scales

Dosing / filling

Universal material tester

Tensile / pulling force measurement