



上海松铭传动机械有限公司
SHANGHAI SONGMING TRANSMISSION MACHINERY CO.,LTD



公司简介 | Company brief introduction

上海松铭传动机械有限公司是一家专业研究、设计、制造各种传动类产品的实业型企业，优势产品有：精密万向节、十字传动万向联轴器、梅花弹性联轴器、星型弹性联轴器、弹性膜片联轴器、弹性柱销套联轴器、波纹管联轴器、UL轮胎联轴器、SL十字滑块联轴器，KC链条联轴器、蛇型弹簧联轴器、鼓型齿联轴器、凸缘联轴器产品等，各规格胀紧联结套及锥套皮带轮（SPA、SPB、SPC、SPZ），并承接各种非标传动零部件的加工。我们的产品远销世界各地，为造纸、冶金、纺织、造船、农机、运输、化工、矿山机械、工程机械、轻工机械、汽车制造等行业设备更新、技术进步，提供所需的配套服务。工厂现有建筑面积4000平米，职工60余人，技术人员5人，拥有车、铣、刨、钻、磨、插、滚齿机等30余台，年生产量万余套。

工厂座落在上海松江区东部开发区，地处沪杭、嘉金高速公路，北松公路、车新公路交汇处；紧邻车墩镇上海影视基地，环境优美，地理位置优越，交通十分便利。

了解客户，满足需求。为客户提供正确的产品与服务是我们公司的服务宗旨！欢迎广大新老客户到我司参观指导！

联轴器系列

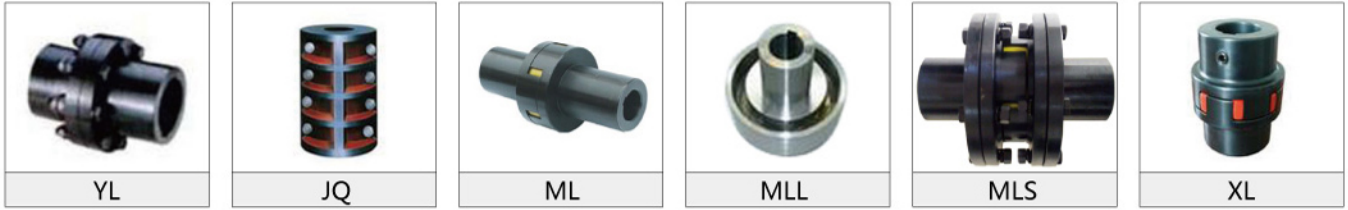

联轴器系列



松铭锥套式欧标皮带轮的原理及特点

锥套皮带轮

■ 锥度锁紧设计原理简介

在锥度配合系统中，最著名的有“International”（国际）和“Morse”（摩斯）这两种系统。前者的锥度为每英尺长度上的直径变化是3.5英寸，锥角为 $15^{\circ}48'$ ，无自锁能力，在没有机械力的约束下，相配对的零件容易分离。典型的Morse锥度用于将钻头或铰孔锥固定到机床的轴心夹具上，其锥度为每英尺长度直径变化0.625英寸，锥角为 $2^{\circ}59'$ ，即使在有润滑条件下，这个锥度也仍然能保持自锁能力。

利用锥度原理将零件紧固于轴上，其实质是将轴向力转化为径向力。这种

结构应能产生最大的紧固力，同时又要使零件易于分离。这只需令锥套取最佳角度（ 8° ）即可达到目的。

如下图1、图2简要解释锥套配合受力情况。当轴向力（ F ）迫使锥套推入轮毂内时，在轴和锥套、锥套和轮毂的界面上产生径向力（ P_s ）和（ P_h ），这些压力可达到 $70-80\text{N/mm}^2$ （ $P_h > P_s$ ）。在轮毂、锥套的锥面上产生周向拉应力及周向压应力，其值可达 $160-190\text{N/mm}^2$ 。在皮带轮与锥套配套设计中，皮带轮和锥套的配合是确定的，锥套轴孔径必须在允许的最大轴孔径以内。



图1



图2

■ 使用优点

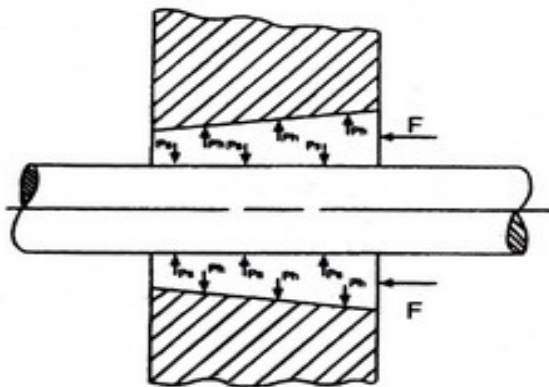
- 安装/拆卸只需1支公制内六角扳手，无需其它任何专用工具，方便快捷（只需大约1分钟便可完成），不会损坏轴和孔的表面。
- 皮带轮和锥套的分离，使轴孔的改变只需改变锥套孔径，增加了产品通用性，大大降低了产品库存种类和成本。
- 其传动的可靠性，在全世界数以百万计

的使用中得到证明。

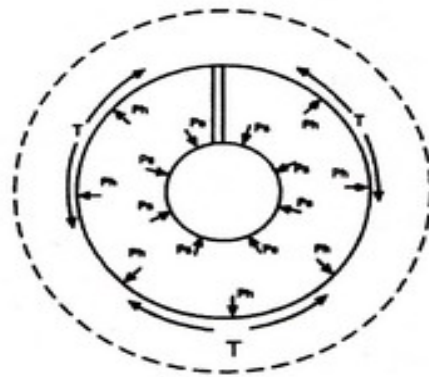
- 允许较宽的轴径公差： $0-0.125\text{mm}$ （ $0"-0.005"$ ）。
- 轻/中轻程度负载允许无键传动。
- 严格按DIN2211标准生产，全部产品经平衡测试及表面防锈处理。

锥套的规格与尺寸

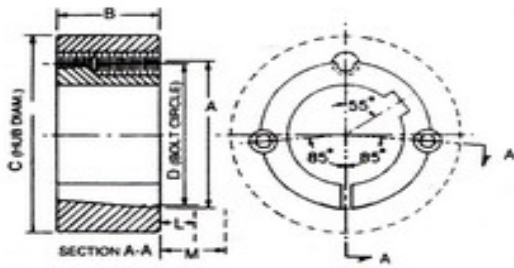

1008~3030

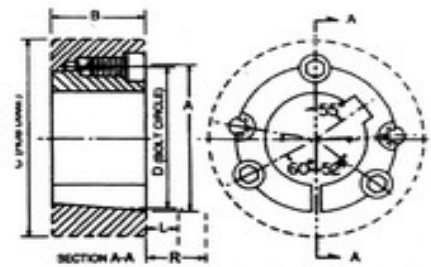

3525~5050

Bushing Number	A	B	C	D	螺丝尺寸 (BSW)
1008	35.2	22.2	60.3	33.7	1/4" X 1/2"
1108	38.4	22.2	63.5	36.9	1/4" X 1/2"
1210	47.6	25.4	92.1	44.5	3/8" X 5/8"
1215	47.6	38.1	79.4	44.5	3/8" X 5/8"
1310	50.8	25.4	95.3	47.6	3/8" X 5/8"
1610	57.2	25.4	101.6	54.0	3/8" X 5/8"
1615	57.2	38.1	88.9	54.0	3/8" X 5/8"
2012	69.9	31.8	120.7	66.7	7/16" X 7/8"
2517	85.7	44.5	139.7	82.6	1/2" X 1"
2525	85.7	63.5	120.7	82.6	3/8" X 1"
3020	108.0	50.8	177.8	101.6	5/8" X 1 1/4"
3030	108.0	76.2	158.8	101.6	7/8" X 1 1/4"
3525	127.0	63.5	197.0	123.0	1/2" X 1 1/2"
3535	127.0	89.0	197.0	123.0	1/2" X 1 1/2"
4030	146.0	76.2	241.0	141.0	5/8" X 1 3/4"
4040	146.0	102.0	241.0	141.0	5/8" X 1 3/4"
4535	161.0	89.0	267.0	156.0	3/4" X 2"
4545	161.0	114.0	267.0	156.0	3/4" X 2"
5040	178.0	101.6	292.0	171.0	7/8" X 2 1/4"
5050	178.0	127.0	292.0	171.0	7/8" X 2 1/4"



锥套的公制孔径与键槽

Metric Bores and Keyways (公制孔径和键槽)

孔径 Bore Dia.	键槽		Shallow Keyway Depth	Bore Sizes Available								
	Width	Depth		1008	1108	1210	1610	1615	2012	2517	3020	3030
9	3	1.4	—	*	*							
10	3	1.4	—	*	*							
11	4	1.8	—	*	*	*						
12	4	1.8	—	*	*	*						
14	5	2.3	—	*	*	*	*	*	*			
15	5	2.3	—	*	*	*	*	*	*			
16	5	2.3	—	*	*	*	*	*	*	*		
18	6	2.8	—	*	*	*	*	*	*	*		
19	6	2.8	—	*	*	*	*	*	*	*		
20	6	2.8	—	*	*	*	*	*	*	*		
22	6	2.8	—	*	*	*	*	*	*	*		
24	8	3.3	1.3	*	*	*	*	*	*	*	*	
25	8	3.3	1.3	*	*	*	*	*	*	*	*	
28	8	3.3	1.3	*	*	*	*	*	*	*	*	
30	8	3.3	—	*	*	*	*	*	*	*	*	
32	10	3.3	—	*	*	*	*	*	*	*	*	*
35	10	3.3	—	*	*	*	*	*	*	*	*	*
38	10	3.3	—	*	*	*	*	*	*	*	*	*
40	12	3.3	—	*	*	*	*	*	*	*	*	*
42	12	3.3	2.2	*	*	*	*	*	*	*	*	*
45	14	3.8	—	*	*	*	*	*	*	*	*	*
48	14	3.8	—	*	*	*	*	*	*	*	*	*
50	14	3.8	—	*	*	*	*	*	*	*	*	*
55	16	4.3	—	*	*	*	*	*	*	*	*	*
60	18	4.4	—	*	*	*	*	*	*	*	*	*
65	18	4.4	—	*	*	*	*	*	*	*	*	*
70	20	4.9	—	*	*	*	*	*	*	*	*	*
75	20	4.9	—	*	*	*	*	*	*	*	*	*

带“*”为有一个浅键槽。

孔径 Bore Dia.	键槽		Shallow Keyway Depth	Bore Sizes Available							
	Width	Depth		3525	3535	4030	4040	4535	4545	5040	5050
35	10	3.3	—	*	*						
38	10	3.3	—	*	*	*	*				
40	12	3.3	—	*	*	*	*				
42	12	3.3	—	*	*	*	*				
45	14	3.8	—	*	*	*	*				
48	14	3.8	—	*	*	*	*				
50	14	3.8	—	*	*	*	*				
55	16	4.3	—	*	*	*	*	*	*		
60	18	4.4	—	*	*	*	*	*	*		
65	18	4.4	—	*	*	*	*	*	*		
70	20	4.9	—	*	*	*	*	*	*	*	*
75	20	4.9	—	*	*	*	*	*	*	*	*
80	22	5.4	—	*	*	*	*	*	*	*	*
85	22	5.4	—	*	*	*	*	*	*	*	*
90	25	5.4	—	*	*	*	*	*	*	*	*
95	25	5.4	—	*	*	*	*	*	*	*	*
100	28	6.4	4.4	*	*	*	*	*	*	*	*
105	28	6.4	—	*	*	*	*	*	*	*	*
110	28	6.4	—	*	*	*	*	*	*	*	*
115	32	7.4	5.4	*	*	*	*	*	*	*	*
120	32	7.4	—	*	*	*	*	*	*	*	*
125	32	7.4	—	*	*	*	*	*	*	*	*
130	32	7.4	—	*	*	*	*	*	*	*	*
140	32	8.4	6.4	*	*	*	*	*	*	*	*

带“*”为有一个浅键槽。

锥套的英制孔径与键槽

Inch Bores and Keyways (英制孔径和键槽)

孔径 Bore Dia.	键槽		Shallow Keyway Depth	Bore Sizes Available								
	Width	Depth		1008	1108	1210	1610	1615	2012	2517	3020	3030
0.375	0.125	0.06	—	*	*							
0.500	0.125	0.06	—	*	*		*	*				
0.625	0.187	0.09	—	*	*	*	*	*				
0.750	0.187	0.09	—	*	*	*	*	*	*			
0.875	0.250	0.12	—	*	*	*	*	*	*	*		
1.000	0.250	0.12	0.052	**	*	*	*	*	*	*		
1.125	0.312	0.11	0.064		*	*	*	*	*	*		
1.250	0.312	0.11	—		*	*	*	*	*	*	*	*
1.375	0.375	0.11	—			*	*	*	*	*	*	*
1.500	0.375	0.11	—				*	*	*	*	*	*
1.625	0.437	0.13	0.103				*	*	*	*	*	*
1.750	0.437	0.13	—					*	*	*	*	*
1.875	0.500	0.13	—					*	*	*	*	*
2.000	0.500	0.13	—					*	*	*	*	*
2.125	0.625	0.18	—						*	*	*	*
2.250	0.625	0.18	—						*	*	*	*
2.375	0.625	0.18	—						*	*	*	*
2.500	0.625	0.18	—						*	*	*	*
2.625	0.750	0.21	—							*	*	*
2.750	0.750	0.21	—							*	*	*
2.875	0.750	0.21	—							*	*	*
3.000	0.750	0.21	—							*	*	*

带“*”为有一个浅键槽。

孔径 Bore Dia.	键槽		Shallow Keyway Depth	Bore Sizes Available								
	Width	Depth		3525	3535	4030	4040	4535	4545	5040	5050	
1.500	0.375	0.11	—	*	*							
1.625	0.437	0.13	—	*	*							
1.750	0.437	0.13	—	*	*	*	*					
1.875	0.500	0.13	—	*	*	*	*					
2.000	0.500	0.13	—	*	*	*	*					
2.125	0.625	0.18	—	*	*	*	*	*	*			
2.250	0.625	0.18	—	*	*	*	*	*	*			
2.375	0.625	0.18	—	*	*	*	*	*	*			
2.500	0.625	0.18	—	*	*	*	*	*	*			
2.625	0.750	0.21	—	*	*	*	*	*	*	*	*	*
2.750	0.750	0.21	—	*	*	*	*	*	*	*	*	*
2.875	0.750	0.21	—	*	*	*	*	*	*	*	*	*
3.000	0.750	0.21	—	*	*	*	*	*	*	*	*	*
3.125	0.875	0.26	—	*	*	*	*	*	*	*	*	*
3.250	0.875	0.26	—	*	*	*	*	*	*	*	*	*
3.375	0.875	0.26	—	*	*	*	*	*	*	*	*	*
3.500	0.875	0.26	—	*	*	*	*	*	*	*	*	*
3.750	1.000	0.32	0.245	**		*	*	*	*	*	*	*
4.000	1.000	0.32	0.155	**		*	*	*	*	*	*	*
4.250	1.250	0.37	—			*	*	*	*	*	*	*
4500	1.250	0.37	0.255			*	*	*	*	*	*	*
4.750	1.250	0.37	—			*	*	*	*	*	*	*
5.000	1.250	0.37	0.258				*	*	*	*	*	*

带“*”为有一个浅键槽。

锥套皮带轮的安装与拆卸方法

锥套皮带轮安装与拆卸

安装:

1. 消除锥套、皮带轮相互配合面的污垢，将锥套放入皮带轮。
2. 用少许油润滑螺纹和螺钉的尖端，将螺钉松松的放入皮带轮与锥套螺钉孔内（见下图所示安装孔）。
3. 将轴清除干净并将皮带轮、锥套（组件）装到轴上，置于理想位置。
4. 利用内六角扳手交替拧紧各螺钉，直至达到下表所需扭矩。
5. 如果要装键，须将键置于轴的键槽上，然后再装配组件。
6. 在负荷下运行一段短时间后，停机检查螺栓的拧紧度。

锥套拧紧力矩

锥套规格	1008	1108	1210	1610	1615	2012	2517	3020	3030	3525	3535	4043	4040	4535	4545	5040	5050
螺栓拧紧 扭矩 (Nm)	5.6	5.6	20	20	20	30	50	90	90	115	115	170	170	190	190	270	270
螺栓 详情	数量	2	2	2	2	2	2	2	2	3	3	3	3	3	3	3	3
	规格 (BSW)	1/4"	1/4"	3/8"	3/8"	3/8"	7/16"	1/2"	5/8"	5/8"	1/2"	5/8"	5/8"	3/4"	3/4"	7/8"	7/8"
	六角凹头 规格 (mm)	3	3	5	5	5	6	6	8	8	10	10	12	12	14	14	14
大端直径 (mm)	35.0	38.0	47.5	57.0	57.0	70.0	85.5	108.0	108.0	127.0	127.0	146.0	146.0	162.0	162.0	177.5	177.5
近似重量 (kg)	0.1	0.1	0.2	0.3	0.5	0.7	1.5	2.7	3.6	3.8	5.0	5.6	7.7	7.5	10.0	11.1	14.0

拆卸:

1. 拧松所有螺钉，取出其中一个或两个螺钉，用油润滑螺纹和螺钉，放入下图所示的拆卸孔内。
2. 交替拧紧螺钉至锥套在皮带轮内松开，直至轴上可自由移动。
3. 从轴上移走皮带轮与锥套。

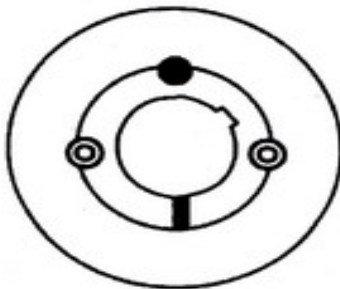

1008~3030

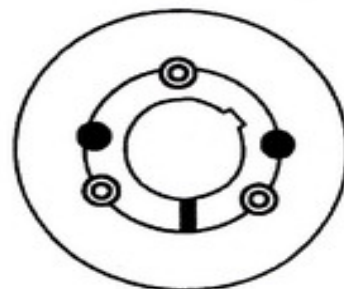

3525~5050

注: ◎ 为安装孔 ● 为拆卸孔

皮带轮的槽形图

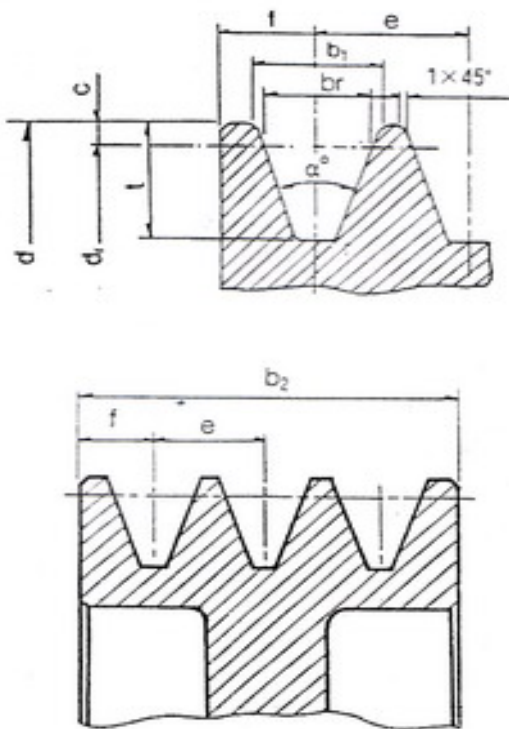

槽形	dr 节径	α	br	b ₁	c	t	e	f
SPZ	$\begin{matrix} \geq 80 \\ < 180 \end{matrix}$	$\begin{matrix} 34 \\ 38 \end{matrix}$	8.5	9.7	2	11	12	8
SPA	$\begin{matrix} \geq 118 \\ < 118 \end{matrix}$	$\begin{matrix} 34 \\ 38 \end{matrix}$	11	12.7	2.8	13.8	15	10
SPB	$\begin{matrix} \geq 190 \\ < 190 \end{matrix}$	$\begin{matrix} 34 \\ 38 \end{matrix}$	14	16.3	3.5	17.5	19	12.5
SPC	$\begin{matrix} \geq 315 \\ < 315 \end{matrix}$	$\begin{matrix} 34 \\ 38 \end{matrix}$	19	22	4.8	23.8	25.5	17

槽形	带轮总宽 (b ₂)							
	槽数							
	1	2	3	4	5	6	8	10
SPZ	16	28	40	52	64	76	100	124
SPA	20	35	50	65	80	95	125	155
SPB	25	44	63	82	101	120	158	196
SPC	34	59.5	85	110.5	136	161.5	212.5	263.5

皮带轮型号说明

SPB - 400 - 3 - 3535

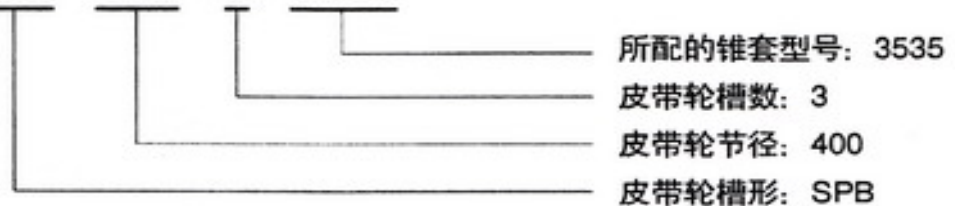

皮带轮选型表

Speed of faster shaft 快速轴转速 转/分	Minimum Pulley Diameter (mm) 最小皮带轮直径(mm)																			
	Design Power (kW) 设计功率(kW)																			
	up to 1	3.0	4.0	5.0	7.5	10.0	15.0	20.0	25	30	40	50	60	75	90	110	130	150	200	250
500	56	90	100	112	125	140	180	200	212	236	250	280	280	315	375	400	450	475	500	560
600	56	85	90	100	112	125	140	180	200	212	224	250	265	280	300	335	375	400	475	500
720	56	80	85	90	100	106	132	150	160	170	200	236	250	265	280	300	335	375	450	500
960	56	75	80	85	95	100	112	132	150	180	180	200	224	250	280	280	300	335	400	450
1200	56	71	80	80	95	95	106	118	132	150	160	180	200	236	236	250	265	300	335	355
1440	56	63	75	80	85	85	100	112	125	140	160	170	190	212	236	236	250	280	315	335
1800	56	63	71	75	80	85	95	106	112	125	150	160	170	190	212	224	236	265	300	335
2880	56	60	67	67	80	80	85	90	100	112	125	140	160	170	180	212	224	236		

*此表仅供选择时的指南。当使用小电动机皮带轮时，必须仔细考虑轴承负荷。

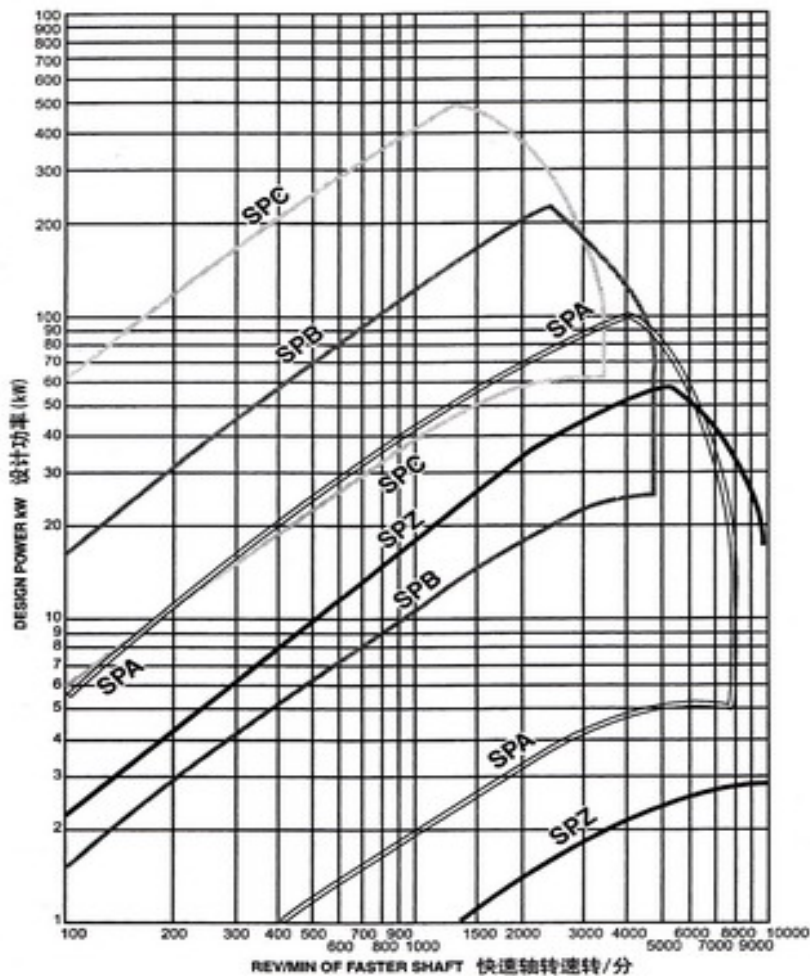

SPZ

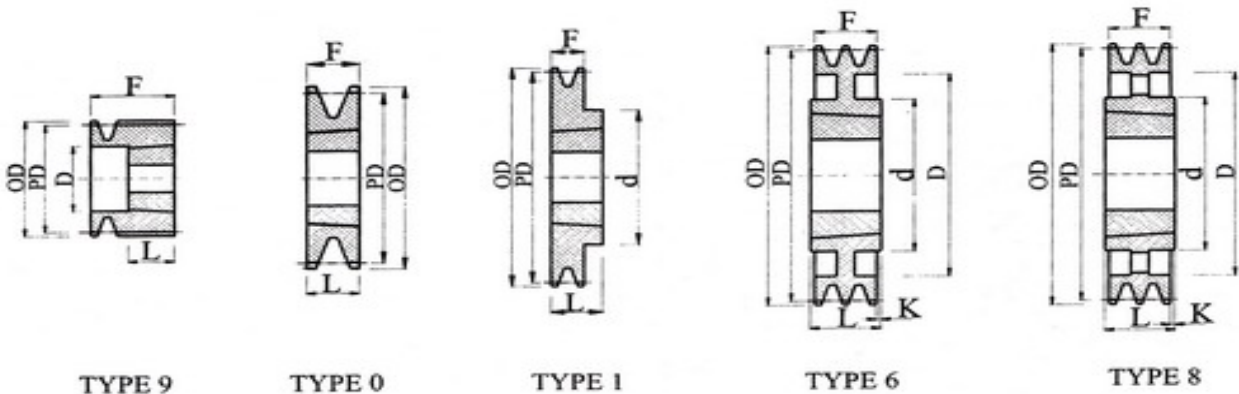

1 GROOVE										
型号 PART NO.	节径 P. D.	外径 O. D.	图例 TYPE	锥套 BUSH NO.	最大孔径 MAX BORE	F	D	K	L	d
SPZ 50-01	50.0	54.6	9	1008	25	37	28	-	22	-
SPZ 56-01	56.0	60.6	9	1008	25	37	23	-	22	-
SPZ 60-01	60.0	64.6	0	1008	25	22	-	-	22	-
SPZ 63-01	63.0	67.6	1	1108	28	16	-	-	22	62
SPZ 67-01	67.0	71.6	1	1108	28	16	-	-	22	62
SPZ 71-01	71.0	75.6	1	1108	28	16	-	-	22	62
SPZ 75-01	75.0	79.6	1	1108	28	16	-	-	22	62
SPZ 80-01	80.0	84.6	1	1210	32	16	-	-	25	75
SPZ 85-01	85.0	89.6	1	1210	32	16	-	-	25	75
SPZ 90-01	90.0	94.6	1	1210	32	16	-	-	25	75
SPZ 95-01	95.0	99.6	1	1210	32	16	-	-	25	75
SPZ 100-01	100.0	104.6	1	1210	32	16	-	-	25	75
SPZ 106-01	106.0	110.6	1	1610	42	16	-	-	25	80
SPZ 112-01	112.0	116.6	1	1610	42	16	-	-	25	80
SPZ 118-01	118.0	122.6	1	1610	42	16	-	-	25	80
SPZ 125-01	125.0	129.6	1	1610	42	16	-	-	25	80
SPZ 132-01	132.0	136.6	1	1610	42	16	-	-	25	80
SPZ 140-01	140.0	144.6	1	1610	42	16	-	-	25	80
SPZ 150-01	150.0	154.6	1	1610	42	16	-	-	25	80
SPZ 160-01	160.0	164.6	1	1610	42	16	-	-	25	80
SPZ 170-01	170.0	174.6	1	1610	42	16	-	-	25	80
SPZ 180-01	180.0	184.6	6	1610	42	16	152	-	25	80
SPZ 190-01	190.0	194.6	6	1610	42	16	162	-	25	80
SPZ 200-01	200.0	204.6	6	2012	50	16	172	-	32	108
SPZ 212-01	212.0	216.6	6	2012	50	16	182	-	32	108
SPZ 224-01	224.0	228.6	6	2012	50	16	196	-	32	108
SPZ 250-01	250.0	254.6	6	2012	50	16	222	-	32	108
SPZ 280-01	280.0	284.6	8	2012	50	16	252	8	32	112
SPZ 315-01	315.0	319.6	8	2012	50	16	286	8	32	112
SPZ 355-01	355.0	359.6	8	2012	50	16	326	8	32	112
SPZ 400-01	400.0	404.6	8	2012	50	16	371	8	32	112
SPZ 450-01	450.0	454.6	8	2517	60	16	421	14.5	45	125
SPZ 500-01	500.0	504.6	8	2517	60	16	471	14.5	45	125

SPZ

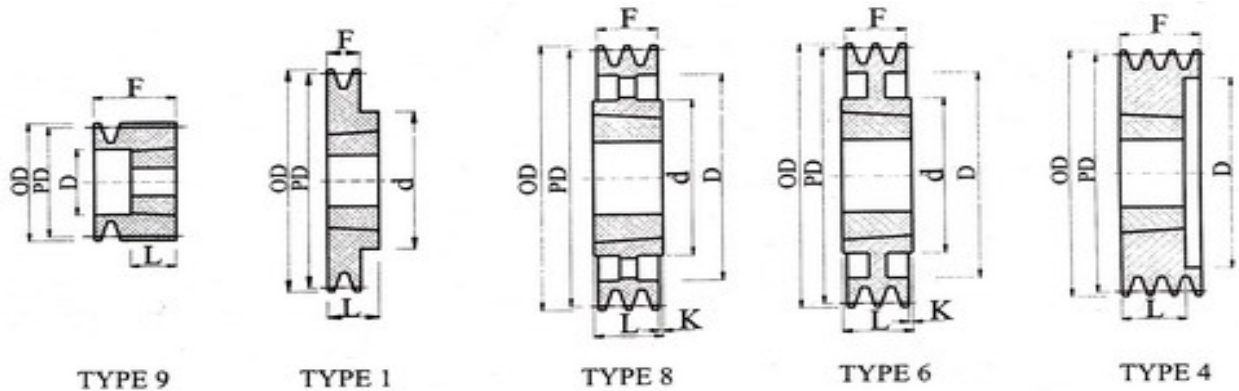

2 GROOVE										
型号 PART NO.	节径 P.D.	外径 O.D.	图例 TYPE	锥套 BUSH NO.	最大孔径 MAX BORE	F	D	K	L	d
SPZ 50-02	50.0	54.6	9	1008	25	49	28	-	22	-
SPZ 56-02	56.0	60.6	9	1108	28	49	35	-	22	-
SPZ 60-02	60.0	64.6	9	1108	28	49	36	-	22	-
SPZ 63-02	63.0	67.6	4	1108	28	28	40	-	22	-
SPZ 67-02	67.0	71.6	4	1108	28	28	42	-	22	-
SPZ 71-02	71.0	75.6	4	1108	28	28	42	-	22	-
SPZ 75-02	75.0	79.6	4	1210	32	28	51	-	25	-
SPZ 80-02	80.0	84.6	4	1210	32	28	51	-	25	-
SPZ 85-02	85.0	89.6	4	1610	42	28	60	-	25	-
SPZ 90-02	90.0	94.6	4	1610	42	28	61	-	25	-
SPZ 95-02	95.0	99.6	4	1610	42	28	66	-	25	-
SPZ 100-02	100.0	104.6	4	1610	42	28	71	-	25	-
SPZ 106-02	106.0	110.6	4	1610	42	28	76	-	25	-
SPZ 112-02	112.0	116.6	4	1610	42	28	84	-	25	-
SPZ 118-02	118.0	122.6	4	1610	42	28	90	-	25	-
SPZ 125-02	125.0	129.6	4	1610	42	28	97	-	25	-
SPZ 132-02	132.0	136.6	4	1610	42	28	104	-	25	-
SPZ 140-02	140.0	144.6	4	1610	42	28	112	-	25	-
SPZ 150-02	150.0	154.6	1	2012	50	28	-	-	32	100
SPZ 160-02	160.0	164.6	1	2012	50	28	-	-	32	100
SPZ 170-02	170.0	174.6	6	2012	50	28	142	-	32	100
SPZ 180-02	180.0	184.6	6	2012	50	28	152	-	32	108
SPZ 190-02	190.0	194.6	6	2012	50	28	162	-	32	108
SPZ 200-02	200.0	204.6	6	2012	50	28	172	-	32	108
SPZ 212-02	212.0	216.6	6	2012	50	28	182	-	32	108
SPZ 224-02	224.0	228.6	6	2012	50	28	196	-	32	108
SPZ 250-02	250.0	254.6	6	2012	50	28	222	-	32	108
SPZ 280-02	280.0	284.6	8	2012	50	28	252	-	32	112
SPZ 315-02	315.0	319.6	8	2012	50	28	286	-	32	112
SPZ 355-02	355.0	359.6	8	2012	50	28	326	-	32	112
SPZ 400-02	400.0	404.6	8	2517	60	28	371	-	45	125
SPZ 450-02	450.0	454.6	8	2517	60	28	421	-	45	125
SPZ 500-02	500.0	504.6	8	2517	60	28	471	-	45	125

SPZ

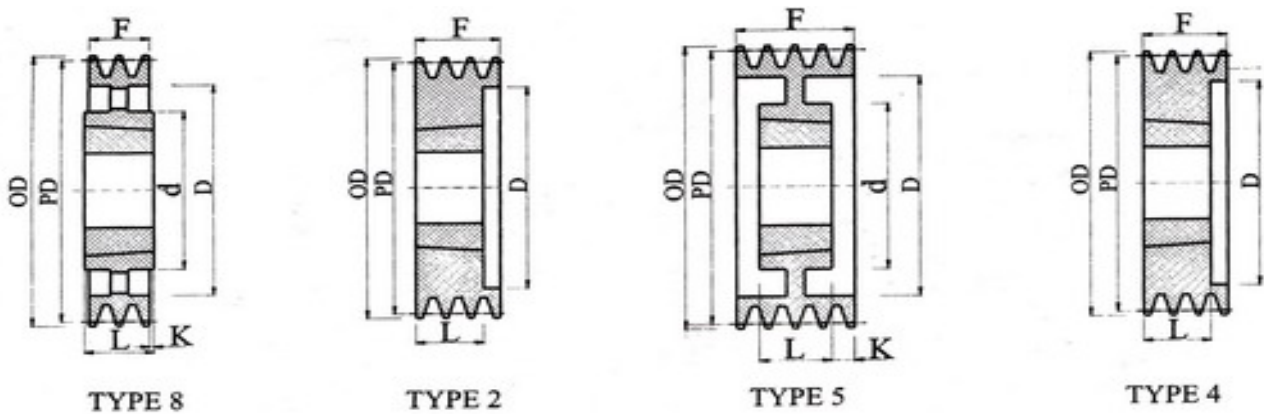

3 GROOVE										
型号 PART NO.	节径 P.D.	外径 O.D.	图例 TYPE	锥套 BUSH NO.	最大孔径 MAX BORE	F	D	K	L	d
SPZ 63-03	63.0	67.6	4	1108	28	40	40	-	22	-
SPZ 67-03	67.0	71.6	4	1108	28	40	42	-	22	-
SPZ 71-03	71.0	75.6	4	1108	28	40	42	-	22	-
SPZ 75-03	75.0	79.6	4	1210	32	40	48	-	25	-
SPZ 80-03	80.0	84.6	4	1210	32	40	51	-	25	-
SPZ 85-03	85.0	89.6	4	1610	42	40	60	-	25	-
SPZ 90-03	90.0	94.6	4	1610	42	40	61	-	25	-
SPZ 95-03	95.0	99.6	4	1610	42	40	66	-	25	-
SPZ 100-03	100.0	104.6	4	1610	42	40	71	-	25	-
SPZ 106-03	106.0	110.6	4	1610	42	40	78	-	25	-
SPZ 112-03	112.0	116.6	4	2012	50	40	84	-	32	-
SPZ 118-03	118.0	122.6	4	2012	50	40	92	-	32	-
SPZ 125-03	125.0	129.6	4	2012	50	40	97	-	32	-
SPZ 132-03	132.0	136.6	4	2012	50	40	104	-	32	-
SPZ 140-03	140.0	144.6	2	2012	50	40	112	-	32	-
SPZ 150-03	150.0	154.6	2	2012	50	40	122	-	32	-
SPZ 160-03	160.0	164.6	2	2012	50	40	132	-	32	-
SPZ 170-03	170.0	174.6	2	2012	50	40	142	-	32	-
SPZ 180-03	180.0	184.6	2	2012	50	40	152	-	32	-
SPZ 190-03	190.0	194.6	5	2012	50	40	162	-	32	108
SPZ 200-03	200.0	204.6	5	2012	50	40	172	-	32	108
SPZ 212-03	212.0	216.6	5	2012	50	40	182	-	32	108
SPZ 224-03	224.0	228.6	5	2012	50	40	196	4	32	108
SPZ 250-03	250.0	254.6	5	2012	50	40	222	4	32	108
SPZ 280-03	280.0	284.6	8	2517	60	40	252	-	45	125
SPZ 315-03	315.0	319.6	8	2517	60	40	286	-	45	125
SPZ 355-03	355.0	359.6	8	2517	60	40	326	-	45	125
SPZ 400-03	400.0	404.6	8	2517	60	40	371	-	45	125
SPZ 450-03	450.0	454.6	8	2517	60	40	421	-	45	125
SPZ 500-03	500.0	504.6	8	2517	60	40	471	-	45	125
SPZ 630-03	630.0	634.6	8	2517	60	40	601	-	45	125
SPZ 800-03	800.0	804.6	8	3020	75	40	771	5.5	51	155

SPZ

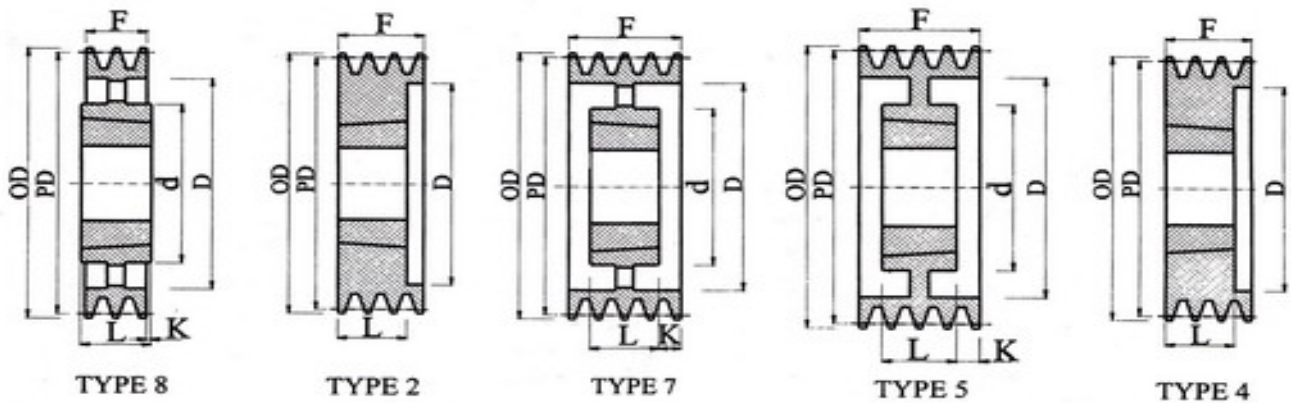

4 GROOVE										
型号 PART NO.	节径 P.D.	外径 O.D.	图例 TYPE	锥套 BUSH NO.	最大孔径 MAX BORE	F	D	K	L	d
SPZ 80-04	80.0	84.6	4	1210	32	52	51	-	25	-
SPZ 85-04	85.0	89.6	4	1610	42	52	56	-	25	-
SPZ 90-04	90.0	94.6	4	1610	42	52	61	-	25	-
SPZ 95-04	95.0	99.6	4	1610	42	52	66	-	25	-
SPZ 100-04	100.0	104.6	4	1610	42	52	74	-	25	-
SPZ 106-04	106.0	110.6	4	1610	42	52	80	-	25	-
SPZ 112-04	112.0	116.6	4	2012	50	52	86	-	32	-
SPZ 118-04	118.0	122.6	2	2012	50	52	92	-	32	-
SPZ 125-04	125.0	129.6	2	2012	50	52	99	-	32	-
SPZ 132-04	132.0	136.6	4	2012	50	52	104	-	32	-
SPZ 140-04	140.0	144.6	2	2012	50	52	112	-	32	-
SPZ 150-04	150.0	154.6	2	2517	60	52	122	-	45	-
SPZ 160-04	160.0	164.6	2	2517	60	52	132	-	45	-
SPZ 170-04	170.0	174.6	2	2517	60	52	142	-	45	-
SPZ 180-04	180.0	184.6	2	2517	60	52	152	-	45	-
SPZ 190-04	190.0	194.6	5	2517	60	52	160	3.5	45	-
SPZ 200-04	200.0	204.6	5	2517	60	52	172	3.5	45	125
SPZ 212-04	212.0	216.6	5	2517	60	52	182	3.5	45	125
SPZ 224-04	224.0	228.6	5	2517	60	52	195	3.5	45	125
SPZ 236-04	236.0	240.6	5	2517	60	52	206	3.5	45	125
SPZ 250-04	250.0	254.6	5	2517	60	52	221	3.5	45	125
SPZ 280-04	280.0	284.6	7	2517	60	52	251	3.5	45	125
SPZ 315-04	315.0	319.6	7	2517	60	52	286	3.5	45	125
SPZ 355-04	355.0	359.6	7	2517	60	52	326	3.5	45	125
SPZ 400-04	400.0	404.6	7	2517	60	52	371	3.5	45	125
SPZ 450-04	450.0	454.6	7	3020	75	52	421	-	51	155
SPZ 500-04	500.0	504.6	7	3020	75	52	471	-	51	155
SPZ 630-04	630.0	634.6	8	3030	75	52	601	12	76	155
SPZ 800-04	800.0	804.6	8	3030	75	52	771	12	76	155

SPZ

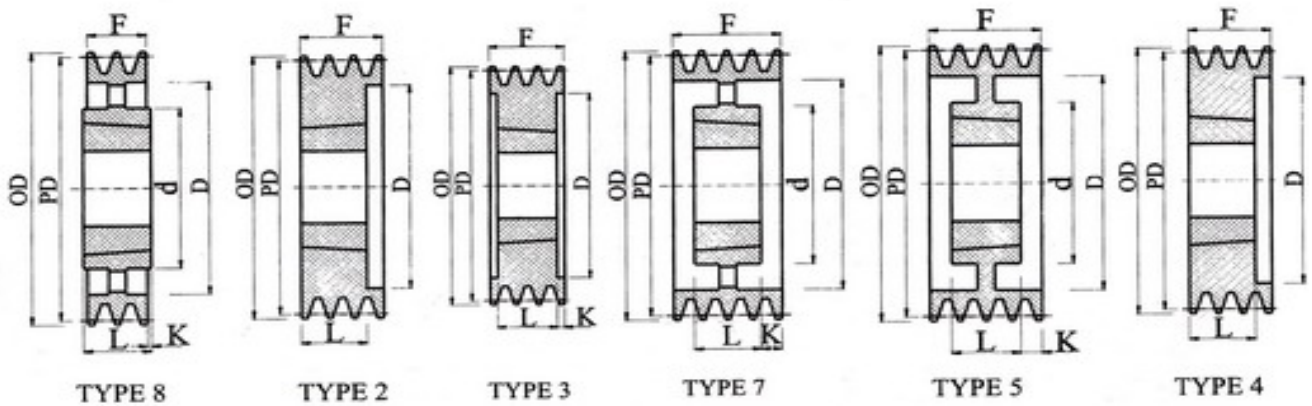

5 GROOVE										
型号 PART NO.	节径 P.D.	外径 O.D.	图例 TYPE	锥套 BUSH NO.	最大孔径 MAX BORE	F	D	K	L	d
SPZ 85-05	85.0	89.6	4	1610	42	64	56	-	25	-
SPZ 90-05	90.0	94.6	4	1610	42	64	61	-	25	-
SPZ 95-05	95.0	99.6	4	1610	42	64	66	-	25	-
SPZ 100-05	100.0	104.6	4	2012	50	64	71	-	32	-
SPZ 106-05	106.0	110.6	4	2012	50	64	77	-	32	-
SPZ 112-05	112.0	116.6	4	2012	50	64	83	-	32	-
SPZ 118-05	118.0	122.6	4	2012	50	64	89	-	32	-
SPZ 125-05	125.0	129.6	4	2012	50	64	96	-	32	-
SPZ 132-05	132.0	136.6	4	2517	60	64	103	-	45	-
SPZ 140-05	140.0	144.6	2	2517	60	64	111	-	45	-
SPZ 150-05	150.0	154.6	2	2517	60	64	121	-	45	-
SPZ 160-05	160.0	164.6	2	2517	60	64	131	-	45	-
SPZ 170-05	170.0	174.6	2	2517	60	64	141	-	45	-
SPZ 180-05	180.0	184.6	2	2517	60	64	151	-	45	-
SPZ 190-05	190.0	194.6	3	2517	60	64	161	9.5	45	125
SPZ 200-05	200.0	204.6	3	2517	60	64	171	9.5	45	125
SPZ 212-05	212.0	216.6	5	2517	60	64	181	9.5	45	125
SPZ 224-05	224.0	228.6	5	2517	60	64	195	9.5	45	125
SPZ 236-05	236.0	240.6	5	2517	60	64	206	9.5	45	125
SPZ 250-05	250.0	254.6	5	2517	60	64	221	9.5	45	125
SPZ 280-05	280.0	284.6	7	2517	60	64	251	9.5	45	125
SPZ 315-05	315.0	319.6	7	2517	60	64	286	9.5	45	125
SPZ 355-05	355.0	359.6	7	2517	60	64	326	9.5	45	125
SPZ 400-05	400.0	404.6	7	3020	75	64	371	6.5	51	155
SPZ 450-05	450.0	454.6	7	3020	75	64	421	6.5	51	155
SPZ 500-05	500.0	504.6	8	3030	75	64	471	6	76	155
SPZ 630-05	630.0	634.6	8	3030	75	64	601	6	76	155
SPZ 710-05	710.0	714.6	8	3535	90	64	680	12.5	89	170
SPZ 800-05	800.0	804.6	8	3535	90	64	771	12.5	89	170

SPZ

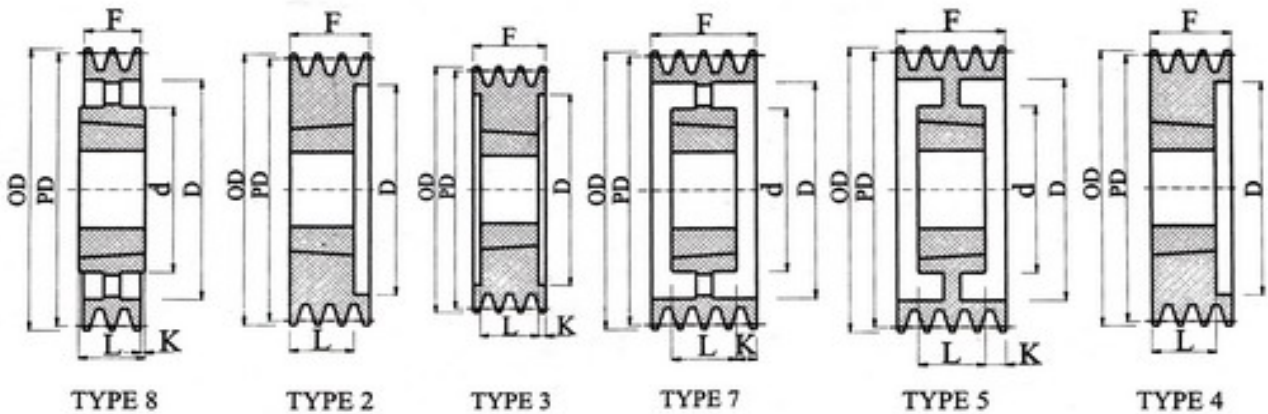

6 GROOVE										
型号 PART NO.	节径 P.D.	外径 O.D.	图例 TYPE	锥套 BUSH NO.	最大孔径 MAX BORE	F	D	K	L	d
SPZ 90-06	90.0	94.6	4	1610	42	76	61	-	25	-
SPZ 95-06	95.0	99.6	4	1610	42	76	66	-	25	-
SPZ 100-06	100.0	104.6	4	2012	50	76	71	-	32	-
SPZ 106-06	106.0	110.6	4	2012	50	76	77	-	32	-
SPZ 112-06	112.0	116.6	4	2012	50	76	83	-	32	-
SPZ 118-06	118.0	122.6	4	2517	60	76	89	-	45	-
SPZ 125-06	125.0	129.6	4	2517	60	76	96	-	45	-
SPZ 132-06	132.0	136.6	4	2517	60	76	103	-	45	-
SPZ 140-06	140.0	144.6	2	2517	60	76	111	-	45	-
SPZ 150-06	150.0	154.6	2	2517	60	76	121	-	45	-
SPZ 160-06	160.0	164.6	2	2517	60	76	131	-	45	-
SPZ 170-06	170.0	174.6	2	2517	60	76	141	-	45	-
SPZ 180-06	180.0	184.6	2	2517	60	76	151	-	45	-
SPZ 190-06	190.0	194.6	3	2517	60	76	161	16	45	125
SPZ 200-06	200.0	204.6	3	2517	60	76	171	16	45	125
SPZ 212-06	212.0	216.6	5	2517	60	76	182	16	45	125
SPZ 224-06	224.0	228.6	5	2517	60	76	195	16	45	125
SPZ 236-06	236.0	240.6	5	2517	60	76	206	16	45	125
SPZ 250-06	250.0	254.6	5	2517	60	76	221	16	45	125
SPZ 280-06	280.0	284.6	7	2517	60	76	251	16	45	125
SPZ 315-06	315.0	319.6	7	2517	60	76	286	16	45	125
SPZ 355-06	355.0	359.6	7	2517	60	76	326	16	45	125
SPZ 400-06	400.0	404.6	7	3030	75	76	371	-	76	155
SPZ 450-06	450.0	454.6	7	3030	75	76	421	-	76	155
SPZ 500-06	500.0	504.6	7	3030	75	76	471	-	76	155
SPZ 630-06	630.0	634.6	8	3535	90	76	601	6.5	89	170
SPZ 710-06	710.0	714.6	8	3535	90	76	680	6.5	89	170
SPZ 800-06	800.0	804.6	8	3535	90	76	771	6.5	89	170

SPZ

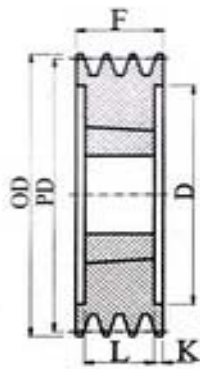

TYPE 3

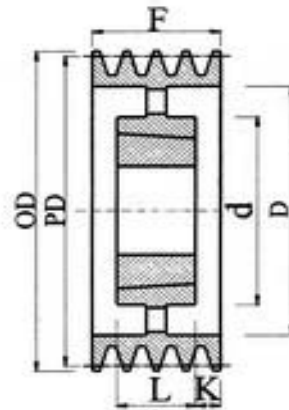

TYPE 7

8 GROOVE										
型号 PART NO.	节径 P.D.	外径 O.D.	图例 TYPE	锥套 BUSH NO.	最大孔径 MAX BORE	F	D	K	L	d
SPZ 140-08	140.0	144.6	3	2517	60	100	111	28	45	-
SPZ 150-08	150.0	154.6	3	2517	60	100	121	28	45	-
SPZ 160-08	160.0	164.6	3	2517	60	100	131	28	45	-
SPZ 180-08	180.0	184.6	3	2517	60	100	151	28	45	-
SPZ 200-08	200.0	204.6	3	3020	75	100	171	25	51	-
SPZ 212-08	212.0	216.6	3	3020	75	100	182	25	51	-
SPZ 224-08	224.0	228.6	3	3020	75	100	195	25	51	-
SPZ 236-08	236.0	240.6	3	3020	75	100	206	25	51	-
SPZ 250-08	250.0	254.6	7	3020	75	100	220	25	51	155
SPZ 280-08	280.0	284.6	7	3020	75	100	250	25	51	155
SPZ 315-08	315.0	319.6	7	3020	75	100	285	25	51	155
SPZ 355-08	355.0	359.6	7	3030	75	100	325	12	76	155
SPZ 400-08	400.0	404.6	7	3030	75	100	370	12	76	155
SPZ 450-08	450.0	454.6	7	3535	90	100	420	6	89	170
SPZ 500-08	500.0	504.6	7	3535	90	100	470	6	89	170
SPZ 630-08	630.0	634.6	7	3535	90	100	600	6	89	170

SPA

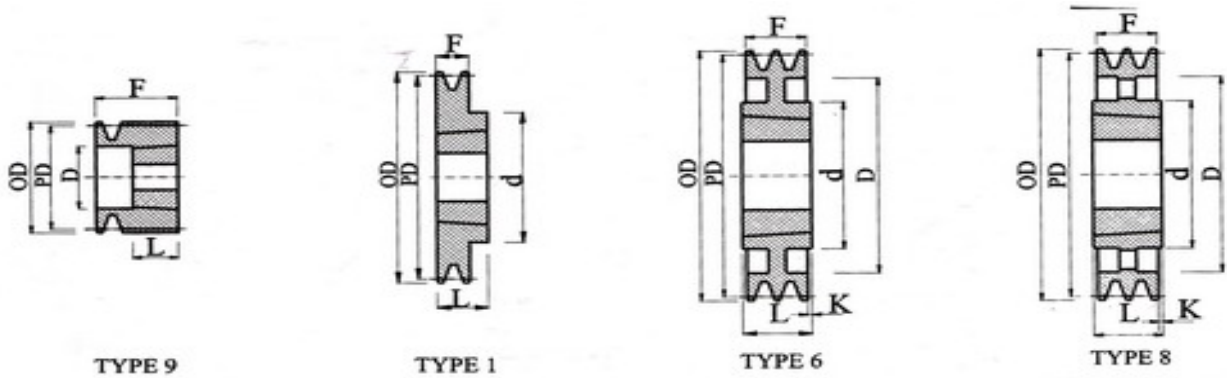

I GROOVE										
型号 PART NO.	节径 P.D.	外径 O.D.	图例 TYPE	锥套 BUSH NO.	最大孔径 MAX BORE	F	D	K	L	d
SPA 63-01	63.0	68.5	9	1108	28	40	34	-	22	-
SPA 67-01	67.0	72.5	1	1108	28	20	-	-	22	62
SPA 71-01	71.0	76.5	1	1108	28	20	-	-	22	62
SPA 75-01	75.0	80.5	1	1108	28	20	-	-	22	62
SPA 80-01	80.0	85.5	1	1210	32	20	-	-	25	75
SPA 85-01	85.0	90.5	1	1210	32	20	-	-	25	75
SPA 90-01	90.0	95.5	1	1210	32	20	-	-	25	75
SPA 95-01	95.0	100.5	1	1210	32	20	-	-	25	75
SPA 100-01	100.0	105.5	1	1610	42	20	-	-	25	80
SPA 106-01	106.0	111.5	1	1610	42	20	-	-	25	80
SPA 112-01	112.0	117.5	1	1610	42	20	-	-	25	80
SPA 118-01	118.0	123.5	1	1610	42	20	-	-	25	80
SPA 125-01	125.0	130.5	1	1610	42	20	-	-	25	80
SPA 132-01	132.0	137.5	1	1610	42	20	-	-	25	80
SPA 140-01	140.0	145.5	1	1610	42	20	-	-	25	80
SPA 150-01	150.0	155.5	1	1610	42	20	-	-	25	80
SPA 160-01	160.0	165.5	1	1610	42	20	-	-	25	80
SPA 170-01	170.0	175.5	1	1610	42	20	-	-	25	80
SPA 180-01	180.0	185.5	6	1610	42	20	145	-	25	80
SPA 190-01	190.0	195.5	6	2012	50	20	155	-	32	100
SPA 200-01	200.0	205.5	6	2012	50	20	165	-	32	100
SPA 212-01	212.0	217.5	6	2012	50	20	175	-	32	100
SPA 224-01	224.0	229.5	6	2012	50	20	189	-	32	100
SPA 236-01	236.0	241.5	6	2012	50	20	202	-	32	100
SPA 250-01	250.0	255.5	6	2012	50	20	215	-	32	100
SPA 265-01	265.0	270.5	6	2012	50	20	230	-	32	112
SPA 280-01	280.0	285.5	8	2012	50	20	245	-	32	112
SPA 300-01	300.0	305.5	8	2012	50	20	265	-	32	112
SPA 315-01	315.0	320.5	8	2012	50	20	280	-	32	112
SPA 335-01	335.0	340.5	8	2012	50	20	320	-	32	112
SPA 355-01	355.0	360.5	8	2012	50	20	320	-	32	112
SPA 375-01	375.0	380.5	8	2012	50	20	340	-	32	112
SPA 400-01	400.0	405.5	8	2012	50	20	365	-	32	112
SPA 425-01	425.0	430.5	8	2012	50	20	390	-	32	112
SPA 450-01	450.0	455.5	8	2012	50	20	415	-	32	112
SPA 500-01	500.0	505.5	8	2517	60	20	465	-	45	125
SPA 530-01	530.0	535.5	8	2517	60	20	495	-	45	125
SPA 560-01	560.0	565.5	8	2517	60	20	525	-	45	125
SPA 630-01	630.0	635.5	8	2517	60	20	595	-	45	125

SPA

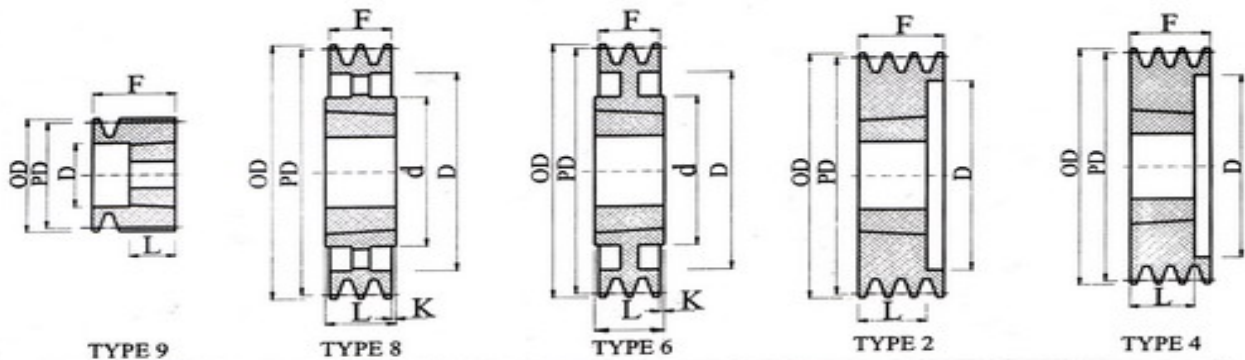

2 GROOVE										
型号 PART NO.	节径 P.D.	外径 O.D.	图例 TYPE	锥套 BUSH NO.	最大孔径 MAX BORE	F	D	K	L	d
SPA 63-02	63.0	68.5	9	1108	28	55	36	-	22	-
SPA 67-02	67.0	72.5	4	1108	28	35	37	-	22	-
SPA 71-02	71.0	76.5	4	1108	28	35	40	-	22	-
SPA 75-02	75.0	80.5	4	1108	28	35	44	-	22	-
SPA 80-02	80.0	85.5	4	1210	32	35	46	-	25	-
SPA 85-02	85.0	90.5	4	1210	32	35	51	-	25	-
SPA 90-02	90.0	95.5	4	1610	42	35	56	-	25	-
SPA 95-02	95.0	100.5	4	1610	42	35	60	-	25	-
SPA 100-02	100.0	105.5	4	1610	42	35	65	-	25	-
SPA 106-02	106.0	111.5	4	1610	42	35	71	-	25	-
SPA 112-02	112.0	117.5	4	1610	42	35	77	-	25	-
SPA 118-02	118.0	123.5	4	1610	42	35	83	-	25	-
SPA 125-02	125.0	130.5	2	1610	42	35	90	-	25	-
SPA 132-02	132.0	137.5	2	2012	50	35	98	-	32	-
SPA 140-02	140.0	145.5	4	2012	50	35	106	-	35	-
SPA 150-02	150.0	155.5	4	2012	50	35	116	-	35	-
SPA 160-02	160.0	165.5	4	2012	50	35	126	-	35	-
SPA 170-02	170.0	175.5	4	2012	50	35	136	-	35	-
SPA 180-02	180.0	185.5	4	2012	50	35	146	-	35	-
SPA 190-02	190.0	195.5	4	2012	50	35	156	-	35	-
SPA 200-02	200.0	205.5	6	2517	60	35	165	-	45	125
SPA 212-02	212.0	217.5	6	2517	60	35	175	-	45	125
SPA 224-02	224.0	229.5	6	2517	60	35	189	-	45	125
SPA 236-02	236.0	241.5	6	2517	60	35	202	-	45	125
SPA 250-02	250.0	255.5	6	2517	60	35	215	-	45	125
SPA 265-02	265.0	270.5	6	2517	60	35	230	-	45	125
SPA 280-02	280.0	285.5	8	2517	60	35	245	-	45	125
SPA 300-02	300.0	305.5	8	2517	60	35	265	-	45	125
SPA 315-02	315.0	320.5	8	2517	60	35	280	-	45	125
SPA 335-02	335.0	340.5	8	2517	60	35	320	-	45	125
SPA 355-02	355.0	360.5	8	2517	60	35	320	-	45	125
SPA 375-02	375.0	380.5	8	2517	60	35	340	-	45	125
SPA 400-02	400.0	405.5	8	2517	60	35	365	-	45	125
SPA 425-02	425.0	430.5	8	2517	60	35	390	-	45	125
SPA 450-02	450.0	455.5	8	2517	60	35	415	-	45	125
SPA 500-02	500.0	505.5	8	2517	60	35	465	-	45	125
SPA 530-02	530.0	535.5	8	3020	75	35	495	-	51	155
SPA 560-02	560.0	565.5	8	3020	75	35	525	-	51	155
SPA 630-02	630.0	635.5	8	3020	75	35	595	-	51	155

SPA

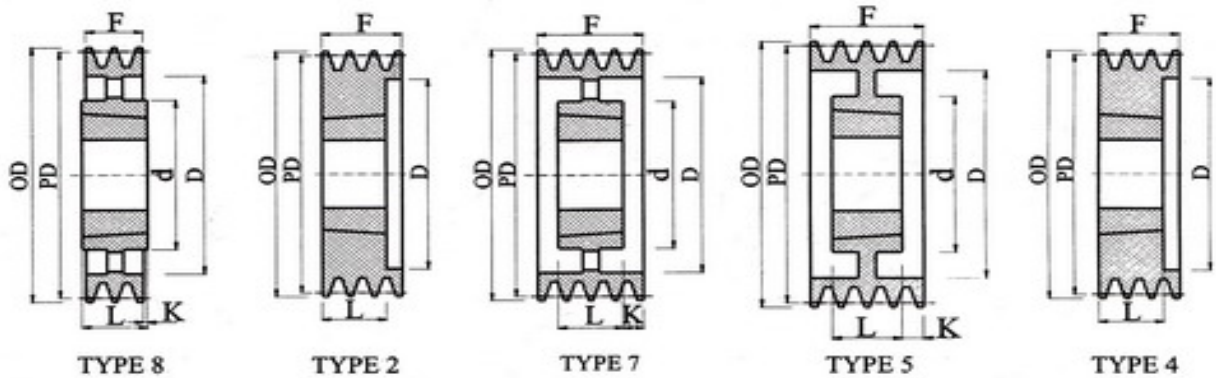

3 GROOVE										
型号 PART NO.	节径 P.D.	外径 O.D.	图例 TYPE	锥套 BUSH NO.	最大孔径 MAX BORE	F	D	K	L	d
SPA 71-03	71.0	76.5	4	1108	28	50	40	-	22	-
SPA 75-03	75.0	80.5	4	1108	28	50	45	-	22	-
SPA 80-03	80.0	85.5	4	1210	32	50	50	-	25	-
SPA 85-03	85.0	90.5	4	1210	32	50	55	-	25	-
SPA 90-03	90.0	95.5	4	1610	42	50	56	-	25	-
SPA 95-03	95.0	100.5	4	1610	42	50	61	-	25	-
SPA 100-03	100.0	105.5	4	1610	42	50	66	-	25	-
SPA 106-03	106.0	111.5	4	1610	42	50	72	-	25	-
SPA 112-03	112.0	117.5	4	2012	50	50	78	-	32	-
SPA 118-03	118.0	123.5	4	2012	50	50	84	-	32	-
SPA 125-03	125.0	130.5	2	2012	50	50	91	-	32	-
SPA 132-03	132.0	137.5	2	2012	50	50	98	-	32	-
SPA 140-03	140.0	145.5	2	2517	60	50	106	-	45	-
SPA 150-03	150.0	155.5	2	2517	60	50	116	-	45	-
SPA 160-03	160.0	165.5	2	2517	60	50	126	-	45	-
SPA 170-03	170.0	175.5	2	2517	60	50	136	-	45	-
SPA 180-03	180.0	185.5	2	2517	60	50	146	-	45	-
SPA 190-03	190.0	195.5	2	2517	60	50	156	-	45	-
SPA 200-03	200.0	205.5	5	2517	60	50	166	-	45	125
SPA 212-03	212.0	217.5	5	2517	60	50	176	-	45	125
SPA 224-03	224.0	229.5	5	2517	60	50	190	2.5	45	125
SPA 236-03	236.0	241.5	5	2517	60	50	202	2.5	45	125
SPA 250-03	250.0	255.5	5	2517	60	50	216	2.5	45	125
SPA 265-03	265.0	270.5	5	2517	60	50	229	2.5	45	125
SPA 280-03	280.0	285.5	7	2517	60	50	246	2.5	45	125
SPA 300-03	300.0	305.5	8	3020	75	50	264	-	51	155
SPA 315-03	315.0	320.5	8	3020	75	50	281	-	51	155
SPA 335-03	335.0	340.5	8	3020	75	50	301	-	51	155
SPA 355-03	355.0	360.5	8	3020	75	50	320	-	51	155
SPA 375-03	375.0	380.5	8	3020	75	50	340	-	51	155
SPA 400-03	400.0	405.5	8	3020	75	50	365	-	51	155
SPA 425-03	425.0	430.5	8	3020	75	50	390	-	51	155
SPA 450-03	450.0	455.5	8	3020	75	50	415	-	51	155
SPA 475-03	475.0	480.5	8	3020	75	50	440	-	51	155
SPA 500-03	500.0	505.5	8	3020	75	50	465	-	51	155
SPA 530-03	530.0	535.5	8	3020	75	50	495	-	51	155
SPA 560-03	560.0	565.5	8	3020	75	50	525	-	51	155
SPA 630-03	630.0	635.5	8	3020	75	50	595	-	51	155
SPA 710-03	710.0	715.5	8	3535	90	50	675	19.5	89	170
SPA 800-03	800.0	805.5	8	3535	90	50	765	19.5	89	170
SPA 900-03	900.0	905.5	8	3535	90	50	866	19.5	89	170
SPA 1000-03	1000.0	1005.5	8	3535	90	50	965	19.5	89	170

SPA

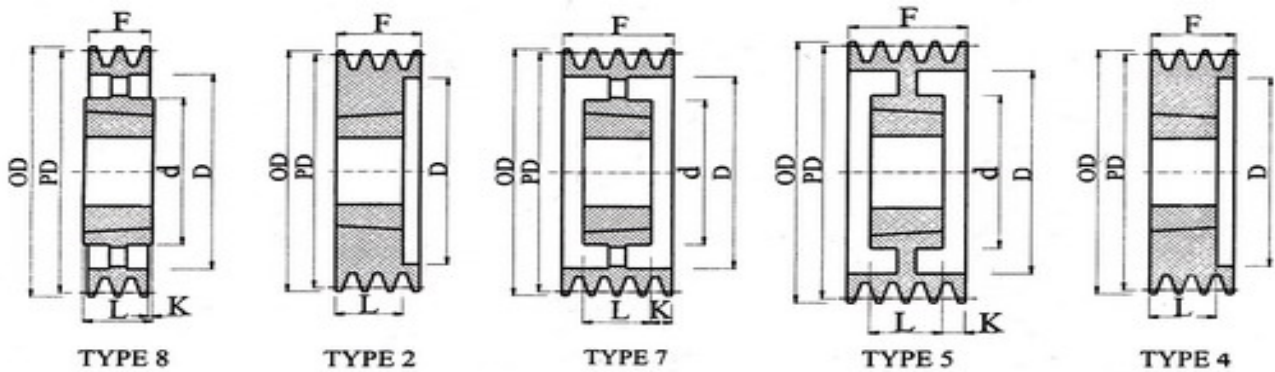

4 GROOVE										
型号 PART NO.	节径 P.D.	外径 O.D.	图例 TYPE	锥套 BUSH NO.	最大孔径 MAX BORE	F	D	K	L	d
SPA 75-04	75.0	80.5	4	1108	28	65	44		22	
SPA 80-04	80.0	85.5	4	1210	32	65	46		25	
SPA 85-04	85.0	90.5	4	1210	32	65	51		25	
SPA 90-04	90.0	95.5	4	1615	42	65	62	-	38	-
SPA 95-04	95.0	100.5	4	1615	42	65	66	-	38	-
SPA 100-04	100.0	105.5	4	1615	42	65	66	-	38	-
SPA 106-04	106.0	111.5	4	2012	50	65	72	-	32	-
SPA 112-04	112.0	117.5	4	2012	50	65	73	-	32	-
SPA 118-04	118.0	123.5	4	2012	50	65	84	-	32	-
SPA 125-04	125.0	130.5	2	2012	50	65	91	-	32	-
SPA 132-04	132.0	137.5	2	2517	60	65	98	-	45	-
SPA 140-04	140.0	145.5	2	2517	60	65	106	-	45	-
SPA 150-04	150.0	155.5	2	2517	60	65	116	-	45	-
SPA 160-04	160.0	165.5	2	2517	60	65	118	-	45	-
SPA 170-04	170.0	175.5	2	2517	60	65	136	-	45	-
SPA 180-04	180.0	185.5	2	2517	60	65	146	-	45	-
SPA 190-04	190.0	195.5	2	2517	60	65	156	-	45	-
SPA 200-04	200.0	205.5	2	3020	75	65	158	-	51	-
SPA 212-04	212.0	217.5	2	3020	75	65	176	-	51	-
SPA 224-04	224.0	229.5	2	3020	75	65	190	-	51	-
SPA 236-04	236.0	241.5	5	3020	75	65	202	7	51	155
SPA 250-04	250.0	255.5	5	3020	75	65	216	7	51	155
SPA 265-04	265.0	270.5	5	3020	75	65	230	7	51	155
SPA 280-04	280.0	285.5	7	3020	75	65	246	7	51	155
SPA 300-04	300.0	305.5	7	3020	75	65	262	7	51	155
SPA 315-04	315.0	320.5	7	3020	75	65	281	7	51	155
SPA 335-04	335.0	340.5	7	3020	75	65	301	7	51	155
SPA 355-04	355.0	360.5	7	3020	75	65	320	7	51	155
SPA 375-04	375.0	380.5	7	3020	75	65	340	7	51	155
SPA 400-04	400.0	405.5	7	3020	75	65	365	7	51	155
SPA 425-04	425.0	430.5	7	3020	75	65	390	7	51	155
SPA 450-04	450.0	455.5	7	3020	75	65	415	7	51	155
SPA 500-04	500.0	505.5	7	3020	75	65	465	7	51	155
SPA 530-04	530.0	535.5	7	3020	75	65	495	7	51	175
SPA 560-04	560.0	565.5	8	3535	90	65	525	12	89	175
SPA 630-04	630.0	635.5	8	3535	90	65	595	12	89	175
SPA 710-04	710.0	715.5	8	3535	90	65	675	12	89	175
SPA 800-04	800.0	805.5	8	3535	90	65	765	12	89	175
SPA 1000-04	1000.0	1005.5	8	4040	100	65	965	19	102	210

SPA

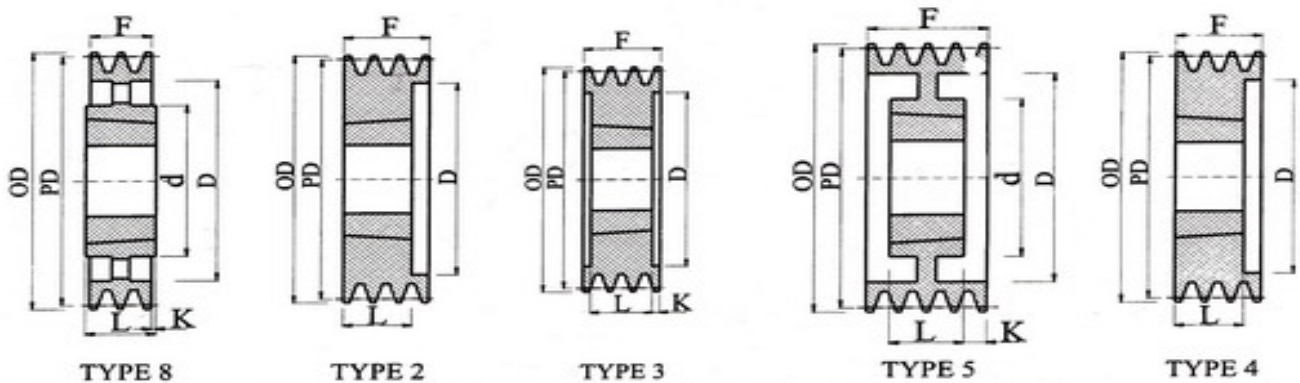

5 GROOVE										
型号 PART NO.	节径 P.D.	外径 O.D.	图例 TYPE	锥套 BUSH NO.	最大孔径 MAX BORE	F	D	K	L	d
SPA 90-05	90.0	95.5	4	1615	42	80	56	-	38	-
SPA 95-05	95.0	100.5	4	1615	42	80	61	-	38	-
SPA 100-05	100.0	105.5	4	1615	42	80	69	-	38	-
SPA 106-05	106.0	111.5	4	2012	50	80	71	-	32	-
SPA 112-05	112.0	117.5	4	2012	50	80	77	-	32	-
SPA 118-05	118.0	123.5	4	2012	50	80	84	-	32	-
SPA 125-05	125.0	130.5	3	2012	50	80	90	24	32	-
SPA 132-05	132.0	137.5	3	2517	60	80	102	17.5	45	-
SPA 140-05	140.0	145.5	3	2517	60	80	108	17.5	45	-
SPA 150-05	150.0	155.5	3	2517	60	80	118	17.5	45	-
SPA 160-05	160.0	165.5	3	2517	60	80	128	17.5	45	-
SPA 170-05	170.0	175.5	3	2517	60	80	138	17.5	45	-
SPA 180-05	180.0	185.5	3	3020	75	80	148	14.5	51	-
SPA 190-05	190.0	195.5	3	3020	75	80	158	14.5	51	-
SPA 200-05	200.0	205.5	3	3020	75	80	168	14.5	51	-
SPA 212-05	212.0	217.5	2	3020	75	80	176	-	51	-
SPA 224-05	224.0	229.5	2	3020	75	80	189	-	51	-
SPA 236-05	236.0	241.5	5	3020	75	80	200	14.5	51	155
SPA 250-05	250.0	255.5	5	3020	75	80	215	14.5	51	155
SPA 265-05	265.0	270.5	5	3020	75	80	230	14.5	51	155
SPA 280-05	280.0	285.5	8	3535	90	80	245	-	89	175
SPA 300-05	300.0	305.5	8	3535	90	80	261	-	89	175
SPA 315-05	315.0	320.5	8	3535	90	80	280	-	89	175
SPA 335-05	335.0	340.5	8	3535	90	80	298	-	89	175
SPA 355-05	355.0	360.5	8	3535	90	80	320	-	89	175
SPA 375-05	375.0	380.5	8	3535	90	80	338	-	89	175
SPA 400-05	400.0	405.5	8	3535	90	80	365	-	89	175
SPA 425-05	425.0	430.5	8	3535	90	80	388	-	89	175
SPA 450-05	450.0	455.5	8	3535	90	80	415	-	89	175
SPA 475-05	475.0	480.5	8	3535	90	80	439	-	89	175
SPA 500-05	500.0	505.5	8	3535	90	80	465	-	89	175
SPA 530-05	530.0	535.5	8	3535	90	80	494	-	89	175
SPA 560-05	560.0	565.5	8	3535	90	80	525	-	89	175
SPA 630-05	630.0	635.5	8	3535	90	80	595	-	89	175
SPA 710-05	710.0	715.5	8	4040	100	80	675	11	102	210
SPA 800-05	800.0	805.5	8	4040	100	80	765	11	102	210
SPA 1000-05	1000.0	1005.5	8	4545	110	80	965	17	114	225

SPA

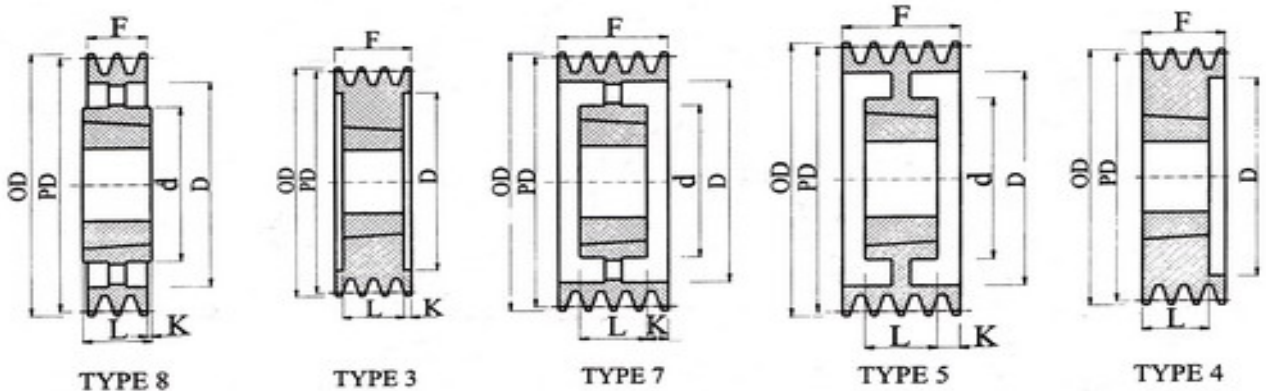

6 GROOVE										
型号 PART NO.	节径 P.D.	外径 O. D.	图例 TYPE	锥套 BUSH NO.	最大孔径 MAX BORE	F	D	K	L	d
SPA 100-06	100.0	105.5	3	1615	42	95	69	28.5	38	-
SPA 106-06	106.0	111.5	4	2012	50	95	71	-	32	-
SPA 112-06	112.0	117.5	4	2012	50	95	77	-	32	-
SPA 118-06	118.0	123.5	4	2012	50	95	84	-	32	-
SPA 125-06	125.0	130.5	3	2012	50	95	90	31.5	32	-
SPA 132-06	132.0	137.5	3	2517	60	95	102	25	45	-
SPA 140-06	140.0	145.5	3	2517	60	95	105	25	45	-
SPA 150-06	150.0	155.5	3	2517	60	95	115	25	45	-
SPA 160-06	160.0	165.5	3	2517	60	95	125	25	45	-
SPA 170-06	170.0	175.5	3	2517	60	95	135	25	45	-
SPA 180-06	180.0	185.5	3	3020	75	95	145	22	51	-
SPA 190-06	190.0	195.5	3	3020	75	95	155	22	51	-
SPA 200-06	200.0	205.5	3	3020	75	95	165	22	51	-
SPA 212-06	212.0	217.5	3	3020	75	95	176	22	51	-
SPA 224-06	224.0	229.5	3	3020	75	95	189	22	51	-
SPA 236-06	236.0	241.5	5	3020	75	95	201	22	51	155
SPA 250-06	250.0	255.5	5	3020	75	95	215	22	51	155
SPA 265-06	265.0	270.5	5	3020	75	95	229	22	51	155
SPA 280-06	280.0	285.5	7	3535	90	95	245	3	89	175
SPA 300-06	300.0	305.5	7	3535	90	95	264	3	89	175
SPA 315-06	315.0	320.5	7	3535	90	95	280	3	89	175
SPA 335-06	335.0	340.5	7	3535	90	95	299	3	89	175
SPA 355-06	355.0	360.5	7	3535	90	95	320	3	89	175
SPA 375-06	375.0	380.5	7	3535	90	95	339	3	89	175
SPA 400-06	400.0	405.5	7	3535	90	95	365	3	89	175
SPA 425-06	425.0	430.5	7	3535	90	95	389	3	89	175
SPA 450-06	450.0	455.5	7	3535	90	95	415	3	89	175
SPA 475-06	475.0	480.5	7	3535	90	95	439	3	89	175
SPA 500-06	500.0	505.5	7	3535	90	95	465	3	89	175
SPA 530-06	530.0	535.5	7	3535	90	95	494	3	89	175
SPA 560-06	560.0	565.5	7	3535	90	95	524	3	89	175
SPA 630-06	630.0	635.5	8	4040	100	95	595	3.5	102	210
SPA 710-06	710.0	715.5	8	4040	100	95	675	3.5	102	210
SPA 800-06	800.0	805.5	8	4040	100	95	765	3.5	102	210
SPA 1000-06	1000.0	1005.5	8	4545	110	95	964	9.5	114	225

SPB

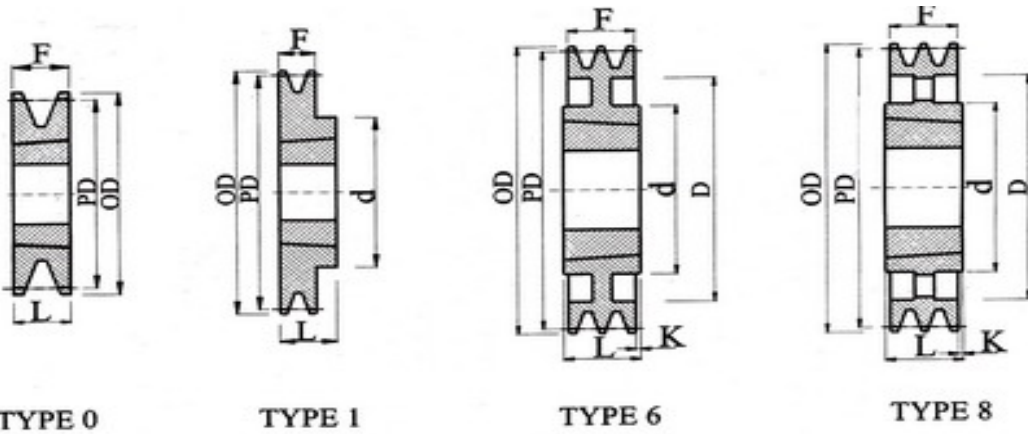

I GROOVE										
型号 PART NO.	节径 P.D.	外径 O.D.	图例 TYPE	锥套 BUSH NO.	最大孔径 MAX BORE	F	D	K	L	d
SPB 100-01	100.0	107.6	0	1610	42	25	-	-	25	-
SPB 106-01	106.0	113.6	0	1610	42	25	-	-	25	-
SPB 112-01	112.0	119.6	0	1610	42	25	-	-	25	-
SPB 118-01	118.0	125.6	0	1610	42	25	-	-	25	-
SPB 125-01	125.0	132.6	0	1610	42	25	-	-	25	-
SPB 132-01	132.0	139.6	0	1610	42	25	-	-	25	-
SPB 140-01	140.0	147.6	0	1610	42	25	-	-	25	-
SPB 150-01	150.0	157.6	0	1610	42	25	-	-	25	-
SPB 160-01	160.0	167.6	0	1610	42	25	-	-	25	-
SPB 170-01	170.0	177.6	0	1610	42	25	-	-	25	-
SPB 180-01	180.0	187.6	0	1610	42	25	-	-	25	-
SPB 190-01	190.0	197.6	1	2012	50	25	-	-	32	100
SPB 200-01	200.0	207.6	6	2012	50	25	157	-	32	100
SPB 212-01	212.0	219.6	6	2012	50	25	169	-	32	100
SPB 224-01	224.0	231.6	6	2012	50	25	181	-	32	100
SPB 236-01	236.0	243.6	6	2012	50	25	193	-	32	100
SPB 250-01	250.0	257.6	6	2012	50	25	207	-	32	100
SPB 265-01	265.0	272.6	6	2012	50	25	218	3.5	32	100
SPB 280-01	280.0	287.6	6	2012	50	25	237	3.5	32	100
SPB 300-01	300.0	307.6	6	2012	50	25	257	3.5	32	100
SPB 315-01	315.0	322.6	6	2012	50	25	272	3.5	32	100
SPB 335-01	335.0	342.6	6	2517	60	25	288	10	45	125
SPB 355-01	355.0	362.6	8	3020	75	25	312	13	51	146
SPB 375-01	375.0	382.6	8	3020	75	25	328	13	51	146
SPB 400-01	400.0	407.6	8	3020	75	25	357	13	51	146
SPB 425-01	425.0	432.6	8	3020	75	25	382	13	51	146
SPB 450-01	450.0	457.6	8	3020	75	25	407	13	51	146
SPB 475-01	475.0	482.6	8	3020	75	25	432	13	51	146
SPB 500-01	500.0	507.6	8	3020	75	25	457	13	51	146
SPB 530-01	530.0	537.6	8	3020	75	25	484	13	51	146
SPB 560-01	560.0	567.6	8	3020	75	25	517	13	51	146
SPB 630-01	630.0	637.6	8	3020	75	25	587	13	51	146

SPB

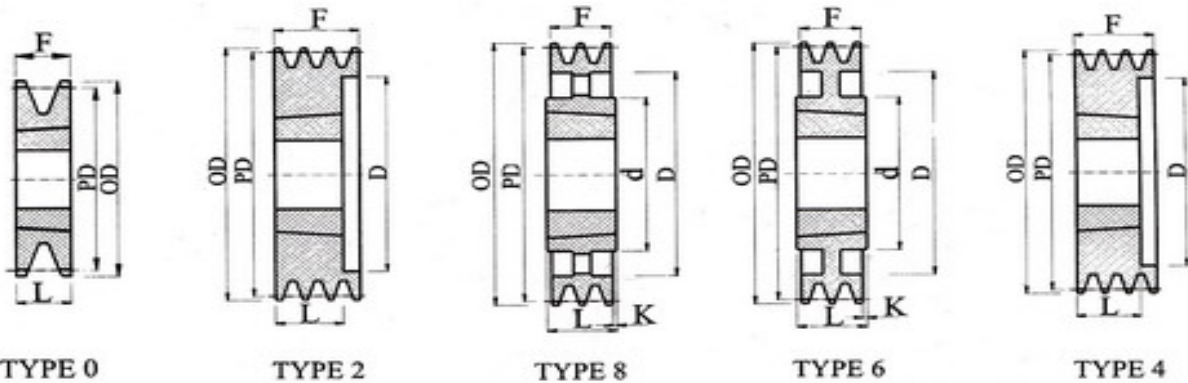

2 GROOVE										
型号 PART NO.	节径 P.D.	外径 O.D.	图例 TYPE	锥套 BUSH NO.	最大孔径 MAX BORE	F	D	K	L	d
SPB 100-02	100.0	107.6	4	1610	42	44	60	-	25	-
SPB 106-02	106.0	113.6	4	1610	42	44	65	-	25	-
SPB 112-02	112.0	119.6	4	1610	42	44	69	-	25	-
SPB 118-02	118.0	125.6	4	1610	42	44	75	-	25	-
SPB 125-02	125.0	132.6	2	2012	50	44	82	-	32	-
SPB 132-02	132.0	139.6	2	2012	50	44	89	-	32	-
SPB 140-02	140.0	147.6	2	2012	50	44	97	-	32	-
SPB 150-02	150.0	157.6	2	2012	50	44	107	-	32	-
SPB 160-02	160.0	167.6	4	2012	50	44	117	-	32	-
SPB 170-02	170.0	177.6	4	2012	50	44	127	-	32	-
SPB 180-02	180.0	187.6	0	2517	60	45	-	-	45	-
SPB 190-02	190.0	197.6	0	2517	60	45	-	-	45	-
SPB 200-02	200.0	207.6	0	2517	60	45	-	-	45	-
SPB 212-02	212.0	219.6	6	2517	60	44	169	-	45	125
SPB 224-02	224.0	231.6	6	2517	60	44	181	-	45	125
SPB 236-02	236.0	243.6	6	2517	60	44	193	-	45	125
SPB 250-02	250.0	257.6	6	2517	60	44	207	-	45	125
SPB 265-02	265.0	272.6	6	2517	60	44	218	-	45	125
SPB 280-02	280.0	287.6	6	2517	60	44	237	-	45	125
SPB 300-02	300.0	307.6	6	2517	60	44	257	-	45	125
SPB 315-02	315.0	322.6	6	2517	60	44	272	-	45	125
SPB 335-02	335.0	342.6	6	2517	60	44	292	-	45	125
SPB 355-02	355.0	362.6	8	3020	75	44	312	-	51	155
SPB 375-02	375.0	382.6	8	3020	75	44	328	-	51	155
SPB 400-02	400.0	407.6	8	3020	75	44	357	-	51	155
SPB 425-02	425.0	432.6	8	3020	75	44	381	-	51	155
SPB 450-02	450.0	457.6	8	3020	75	44	407	-	51	155
SPB 475-02	475.0	482.6	8	3020	75	44	431	-	51	155
SPB 500-02	500.0	507.6	8	3020	75	44	457	-	51	155
SPB 530-02	530.0	537.6	8	3020	75	44	484	-	51	155
SPB 560-02	560.0	567.6	8	3030	75	44	517	16	76	155
SPB 630-02	630.0	637.6	8	3030	75	44	587	16	76	155
SPB 710-02	710.0	717.6	8	3030	75	44	664	16	76	155
SPB 800-02	800.0	807.6	8	3535	90	44	753	22.5	89	175

SPB

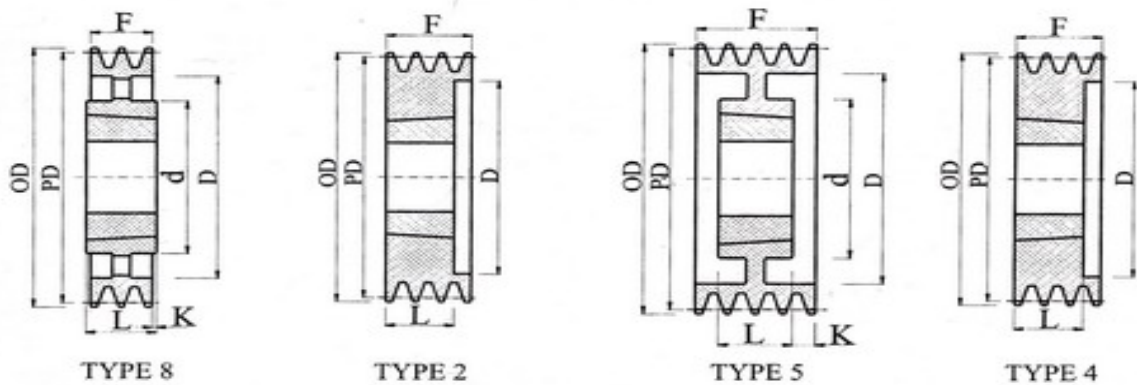

3 GROOVE										
型号 PART NO.	节径 P.D.	外径 O.D.	图例 TYPE	锥套 BUSH NO.	最大孔径 MAX BORE	F	D	K	L	d
SPB 100-03	100.0	107.6	4	1610	42	63	60	-	25	-
SPB 106-03	106.0	113.6	4	1610	42	63	65	-	25	-
SPB 112-03	112.0	119.6	4	1610	42	63	69	-	25	-
SPB 118-03	118.0	125.6	4	1610	42	63	76	-	25	-
SPB 125-03	125.0	132.6	2	2012	50	63	90	-	32	-
SPB 132-03	132.0	139.6	2	2012	50	63	89	-	32	-
SPB 140-03	140.0	147.6	2	2012	50	63	97	-	32	-
SPB 150-03	150.0	157.6	2	2517	60	63	107	-	45	-
SPB 160-03	160.0	167.6	4	2517	60	63	117	-	45	-
SPB 170-03	170.0	177.6	4	2517	60	63	127	-	45	-
SPB 180-03	180.0	187.6	4	2517	60	63	137	-	45	-
SPB 190-03	190.0	197.6	4	2517	60	63	147	-	45	-
SPB 200-03	200.0	207.6	2	2517	60	63	157	-	45	-
SPB 212-03	212.0	219.6	5	2517	60	63	169	-	45	125
SPB 224-03	224.0	231.6	5	2517	60	63	181	-	45	125
SPB 236-03	236.0	243.6	5	2517	60	63	193	-	45	125
SPB 250-03	250.0	257.6	5	3020	75	63	207	-	51	155
SPB 265-03	265.0	272.6	5	3020	75	63	222	-	51	155
SPB 280-03	280.0	287.6	5	3020	75	63	237	6	51	155
SPB 300-03	300.0	307.6	5	3020	75	63	257	6	51	155
SPB 315-03	315.0	322.6	5	3020	75	63	272	6	51	155
SPB 335-03	335.0	342.6	5	3020	75	63	292	6	51	155
SPB 355-03	355.0	362.6	8	3020	75	63	312	6	51	155
SPB 375-03	375.0	382.6	8	3535	90	63	332	-	89	175
SPB 400-03	400.0	407.6	8	3535	90	63	357	-	89	175
SPB 425-03	425.0	432.6	8	3535	90	63	382	-	89	175
SPB 450-03	450.0	457.6	8	3535	90	63	407	-	89	175
SPB 475-03	475.0	482.6	8	3535	90	63	431	13	89	175
SPB 500-03	500.0	507.6	8	3535	90	63	457	13	89	175
SPB 530-03	530.0	537.6	8	3535	90	63	484	13	89	175
SPB 560-03	560.0	567.6	8	3535	90	63	517	13	89	175
SPB 630-03	630.0	637.6	8	3535	90	63	587	13	89	175
SPB 710-03	710.0	717.6	8	3535	90	63	667	13	89	175
SPB 800-03	800.0	807.6	8	3535	90	63	757	13	89	175
SPB 1000-03	1000.0	1007.6	8	4040	100	63	957	19.5	102	210
SPB 1250-03	1250.0	1257.6	8	4040	100	63	1204	19.5	102	210

SPB

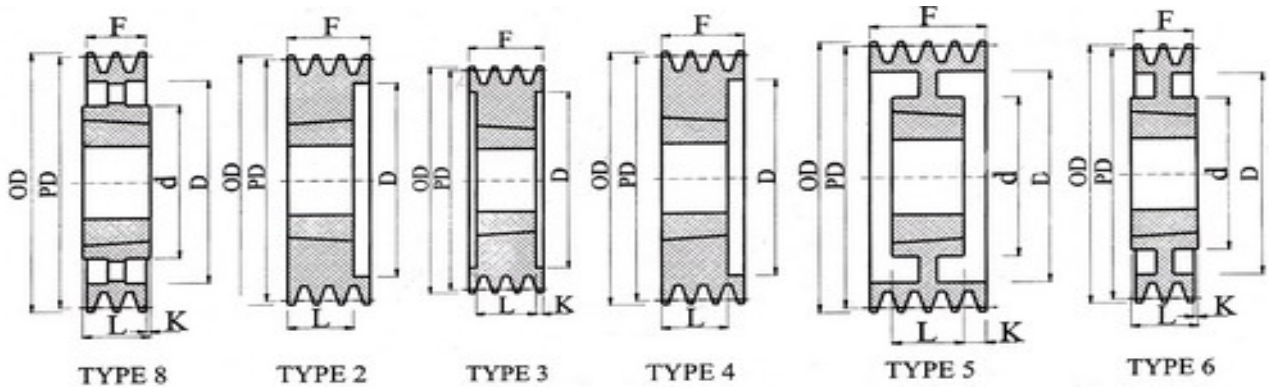

4 GROOVE										
型号 PART NO.	节径 P.D.	外径 O.D.	图例 TYPE	锥套 BUSH NO.	最大孔径 MAX BORE	F	D	K	L	d
SPB 100-04	100.0	107.6	4	1615	42	82	58	-	38	-
SPB 106-04	106.0	113.6	4	1615	42	82	65	-	38	-
SPB 112-04	112.0	119.6	3	1615	42	82	65	22	38	-
SPB 118-04	118.0	125.6	3	1615	42	82	71	22	38	-
SPB 125-04	125.0	132.6	3	2012	50	82	90	25	32	-
SPB 132-04	132.0	139.6	3	2012	50	82	89	25	32	-
SPB 140-04	140.0	147.6	3	2517	60	82	98	19	45	-
SPB 150-04	150.0	157.6	3	2517	60	82	107	19	45	-
SPB 160-04	160.0	167.6	3	2517	60	82	117	19	45	-
SPB 170-04	170.0	177.6	3	2517	60	82	127	19	45	-
SPB 180-04	180.0	187.6	3	2517	60	82	137	19	45	-
SPB 190-04	190.0	197.6	3	2517	60	82	147	19	45	-
SPB 200-04	200.0	207.6	2	3020	75	82	157	-	51	-
SPB 212-04	212.0	219.6	2	3020	75	82	169	-	51	-
SPB 224-04	224.0	231.6	2	3020	75	82	181	-	51	-
SPB 236-04	236.0	243.6	2	3020	75	82	193	-	51	-
SPB 250-04	250.0	257.6	5	3020	75	82	207	-	51	155
SPB 265-04	265.0	272.6	5	3020	75	82	222	16	51	155
SPB 280-04	280.0	287.6	5	3020	75	82	237	16	51	155
SPB 300-04	300.0	307.6	6	3535	90	82	257	-	89	175
SPB 315-04	315.0	322.6	6	3535	90	82	272	-	89	175
SPB 335-04	335.0	342.6	6	3535	90	82	292	-	89	175
SPB 355-04	355.0	362.6	8	3535	90	82	312	-	89	175
SPB 375-04	375.0	382.6	8	3535	90	82	332	-	89	175
SPB 400-04	400.0	407.6	8	3535	90	82	357	-	89	175
SPB 425-04	425.0	432.6	8	3535	90	82	382	-	89	175
SPB 450-04	450.0	457.6	8	3535	90	82	407	-	89	175
SPB 475-04	475.0	482.6	8	3535	90	82	431	-	89	175
SPB 500-04	500.0	507.6	8	3535	90	82	457	-	89	175
SPB 530-04	530.0	537.6	8	3535	90	82	484	-	89	175
SPB 560-04	560.0	567.6	8	3535	90	82	517	-	89	175
SPB 630-04	630.0	637.6	8	3535	90	82	587	-	89	175
SPB 710-04	710.0	717.6	8	3535	90	82	667	-	89	175
SPB 800-04	800.0	807.6	8	4040	100	82	757	10	102	210
SPB 1000-04	1000.0	1007.6	8	4040	100	82	954	10	102	210
SPB 1250-04	1250.0	1257.6	8	4545	110	82	1204	16	114	225

SPB

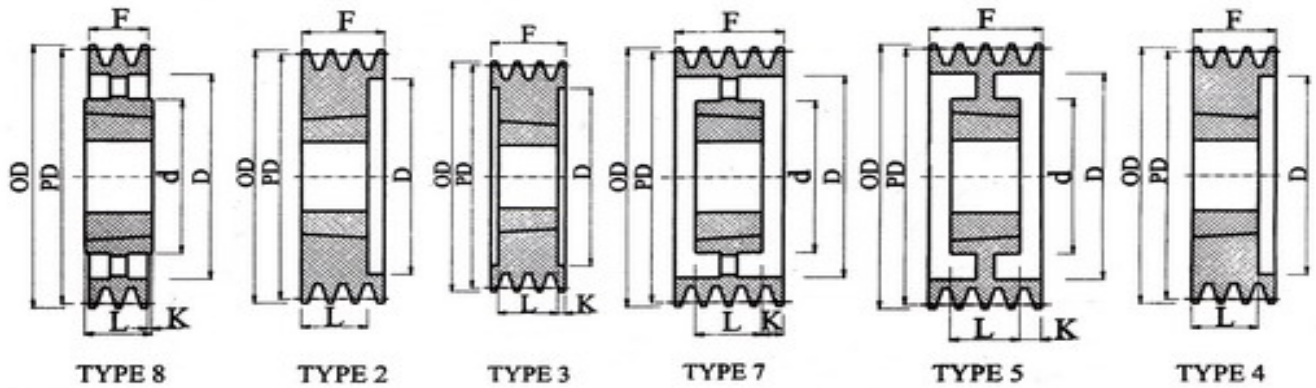

5 GROOVE										
型号 PART NO.	节径 P.D.	外径 O.D.	图例 TYPE	锥套 BUSH NO.	最大孔径 MAX BORE	F	D	K	L	d
SPB 112-05	112.0	119.6	4	2012	50	101	69	-	32	-
SPB 118-05	118.0	125.6	4	2012	50	101	71	-	32	-
SPB 125-05	125.0	132.6	4	2012	50	101	87	-	32	-
SPB 132-05	132.0	139.6	4	2517	60	101	94	-	45	-
SPB 140-05	140.0	147.6	3	2517	60	101	106	28	45	-
SPB 150-05	150.0	157.6	3	2517	60	101	107	28	45	-
SPB 160-05	160.0	167.6	3	2517	60	101	117	28	45	-
SPB 170-05	170.0	177.6	3	3020	75	101	127	25	51	-
SPB 180-05	180.0	187.6	3	3020	75	101	137	25	51	-
SPB 190-05	190.0	197.6	3	3020	75	101	147	25	51	-
SPB 200-05	200.0	207.6	3	3020	75	101	157	25	51	-
SPB 212-05	212.0	219.6	3	3020	75	101	169	25	51	-
SPB 224-05	224.0	231.6	3	3020	75	101	181	25	51	-
SPB 236-05	236.0	243.6	2	3535	90	101	193	-	89	-
SPB 250-05	250.0	257.6	2	3535	90	101	207	-	89	175
SPB 265-05	265.0	272.6	2	3535	90	101	224	-	89	175
SPB 280-05	280.0	287.6	5	3535	90	101	237	6	89	175
SPB 300-05	300.0	307.6	5	3535	90	101	257	6	89	175
SPB 315-05	315.0	322.6	5	3535	90	101	272	6	89	175
SPB 335-05	335.0	342.6	5	3535	90	101	292	6	89	175
SPB 355-05	355.0	362.6	7	3535	90	101	312	6	89	175
SPB 375-05	375.0	382.6	7	3535	90	101	332	6	89	175
SPB 400-05	400.0	407.6	7	3535	90	101	357	6	89	175
SPB 425-05	425.0	432.6	7	3535	90	101	382	6	89	175
SPB 450-05	450.0	457.6	7	3535	90	101	407	6	89	175
SPB 475-05	475.0	482.6	7	3535	90	101	432	6	89	175
SPB 500-05	500.0	507.6	7	3535	90	101	457	6	89	175
SPB 530-05	530.0	537.6	7	3535	90	101	484	6	89	175
SPB 560-05	560.0	567.6	8	4040	100	101	517	-	102	210
SPB 630-05	630.0	637.6	8	4040	100	101	587	-	102	210
SPB 710-05	710.0	717.6	8	4040	100	101	664	-	102	210
SPB 800-05	800.0	807.6	8	4040	100	101	757	-	102	210
SPB 900-05	900.0	907.6	8	4545	110	101	857	-	114	225
SPB 1000-05	1000.0	1007.6	8	4545	110	101	953	-	114	225
SPB 1250-05	1250.0	1257.6	8	4545	110	101	1204	-	114	225

SPB

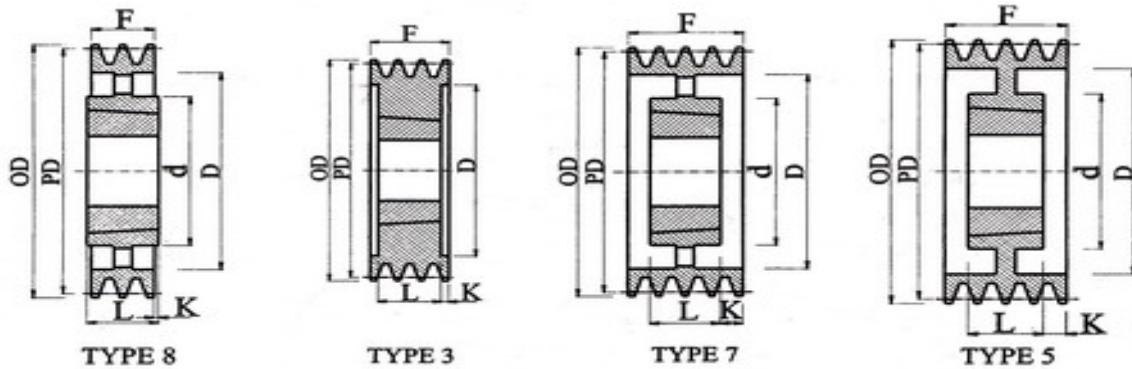

6 GROOVE										
型号 PART NO.	节径 P.D.	外径 O.D.	图例 TYPE	锥套 BUSH NO.	最大孔径 MAX BORE	F	D	K	L	d
SPB 112-06	112.0	119.6	3	2012	50	120	69	44	32	-
SPB 118-06	118.0	125.6	3	2012	50	120	71	44	32	-
SPB 125-06	125.0	132.6	3	2012	50	120	85	44	32	-
SPB 132-06	132.0	139.6	3	2517	60	120	92	38	45	-
SPB 140-06	140.0	147.6	3	2517	60	120	106	38	45	-
SPB 150-06	150.0	157.6	3	2517	60	120	107	38	45	-
SPB 160-06	160.0	167.6	3	3020	75	120	123	35	51	-
SPB 170-06	170.0	177.6	3	3020	75	120	127	35	51	-
SPB 180-06	180.0	187.6	3	3020	75	120	137	35	51	-
SPB 190-06	190.0	197.6	3	3020	75	120	147	35	51	-
SPB 200-06	200.0	207.6	3	3020	75	120	157	35	51	-
SPB 212-06	212.0	219.6	3	3535	90	120	169	16	89	-
SPB 224-06	224.0	231.6	3	3535	90	120	181	16	89	-
SPB 236-06	236.0	243.6	3	3535	90	120	193	16	89	-
SPB 250-06	250.0	257.6	3	3535	90	120	207	16	89	-
SPB 265-06	265.0	272.6	5	3535	90	120	222	16	89	175
SPB 280-06	280.0	287.6	5	3535	90	120	237	16	89	175
SPB 300-06	300.0	307.6	5	3535	90	120	257	16	89	175
SPB 315-06	315.0	322.6	5	3535	90	120	272	16	89	175
SPB 335-06	335.0	342.6	5	3535	90	120	292	16	89	175
SPB 355-06	355.0	362.6	7	3535	90	120	312	16	89	175
SPB 375-06	375.0	382.6	7	3535	90	120	332	16	89	175
SPB 400-06	400.0	407.6	7	3535	90	120	357	16	89	175
SPB 425-06	425.0	432.6	7	3535	90	120	382	16	89	175
SPB 450-06	450.0	457.6	7	4040	100	120	407	9	102	210
SPB 475-06	475.0	482.6	7	4040	100	120	432	9	102	210
SPB 500-06	500.0	507.6	7	4040	100	120	457	9	102	210
SPB 530-06	530.0	537.6	7	4040	100	120	484	9	102	210
SPB 560-06	560.0	567.6	7	4040	100	120	517	9	102	210
SPB 630-06	630.0	637.6	7	4040	100	120	587	9	102	210
SPB 710-06	710.0	717.6	7	4545	110	120	664	3	102	225
SPB 800-06	800.0	807.6	7	4545	110	120	757	3	114	225
SPB 900-06	900.0	907.6	7	4545	110	120	857	3	114	225
SPB 1000-06	1000.0	1007.6	7	4545	110	120	953	3	114	225
SPB 1250-06	1250.0	1257.6	8	5050	125	120	1204	4	127	245

SPB

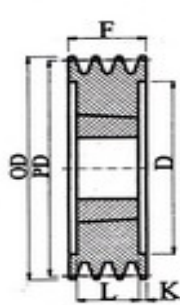

TYPE 3

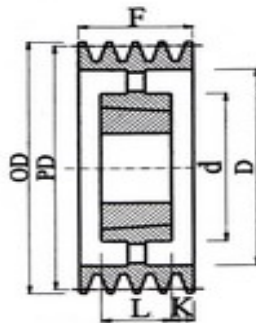

TYPE 7

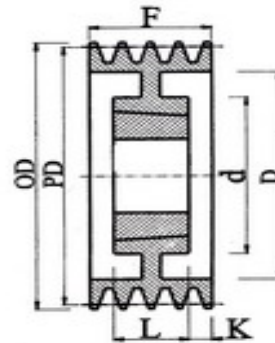

TYPE 5

8 GROOVE										
型号 PART NO.	节径 P.D.	外径 O.D.	图例 TYPE	锥套 BUSH NO.	最大孔径 MAX BORE	F	D	K	L	d
SPB 160-08	160.6	167.6	3	3020	75	158	117	54	51	-
SPB 170-08	170.6	177.6	3	3030	75	158	123	41	76	-
SPB 180-08	180.6	187.6	3	3030	75	158	137	41	76	-
SPB 190-08	190.6	197.6	3	3030	75	158	147	41	76	-
SPB 200-08	200.6	207.6	3	3535	90	158	157	34.5	89	-
SPB 212-08	212.6	219.6	3	3535	90	158	169	34.5	89	-
SPB 224-08	224.6	231.6	3	3535	90	158	181	34.5	89	-
SPB 236-08	236.6	243.6	3	3535	90	158	193	34.5	89	-
SPB 250-08	250.6	257.6	3	3535	90	158	207	34.5	89	-
SPB 265-08	265.0	272.0	3	3535	90	158	218	34.5	89	-
SPB 280-08	280.6	287.6	5	3535	90	158	237	34.5	89	175
SPB 300-08	300.6	307.6	5	3535	90	158	257	34.5	89	175
SPB 315-08	315.6	322.6	5	3535	90	158	272	34.5	89	175
SPB 335-08	335.6	342.6	5	3535	90	158	292	34.5	89	175
SPB 355-08	355.6	362.6	5	3535	90	158	312	34.5	89	175
SPB 375-08	375.0	382.0	5	3535	90	158	335	34.5	89	175
SPB 400-08	400.6	407.6	7	4040	100	158	357	28	102	210
SPB 425-08	425.0	432.0	7	4040	100	158	381	28	102	210
SPB 450-08	450.6	457.6	7	4040	100	158	407	28	102	210
SPB 500-08	500.6	507.6	7	4040	100	158	457	28	102	210
SPB 530-08	530.0	537.0	7	4040	100	158	484	28	102	210
SPB 560-08	560.6	567.6	7	4545	110	158	517	22	114	225
SPB 630-08	630.6	637.6	7	4545	110	158	587	22	114	225
SPB 710-08	710.6	717.6	7	4545	110	158	667	22	114	225
SPB 800-08	800.6	807.6	7	4545	110	158	757	22	114	225
SPB 900-08	900.6	907.6	7	4545	110	158	857	22	114	225
SPB 1000-08	1000.6	1007.6	7	5050	125	158	957	15.5	127	245
SPB 1250-08	1250.6	1257.6	7	5050	125	158	1207	15.5	127	245

SPB

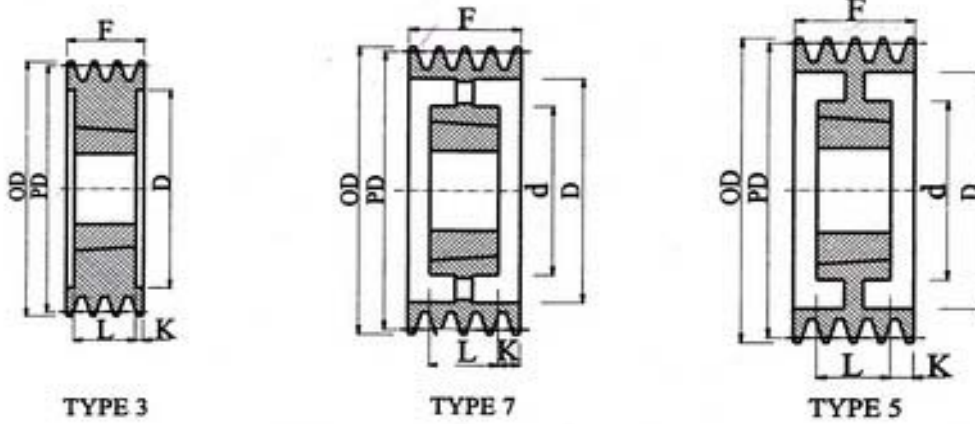

10 GROOVE										
型号 PART NO.	节径 P.D.	外径 O.D.	图例 TYPE	锥套 BUSH NO.	最大孔径 MAX BORE	F	D	K	L	d
SPB 224-10	224.6	231.6	3	3535	90	196	183	53.5	89	-
SPB 236-10	236.6	243.6	3	3535	90	196	197	53.5	89	-
SPB 250-10	250.6	257.6	3	3535	90	196	211	53.5	89	-
SPB 280-10	280.6	287.6	5	3535	90	196	229	53.5	89	175
SPB 315-10	315.6	322.6	5	3535	90	196	265	53.5	89	175
SPB 335-10	335.6	342.6	5	4040	100	196	285	47	102	210
SPB 355-10	355.6	362.6	5	4040	100	196	310	47	102	210
SPB 400-10	400.6	407.6	5	4040	100	196	400	47	102	210
SPB 450-10	450.6	457.6	7	4545	110	196	407	41	114	225
SPB 500-10	500.6	507.6	7	4545	110	196	449	41	114	225
SPB 560-10	560.6	567.6	7	4545	110	196	517	41	114	225
SPB 630-10	630.6	637.6	7	4545	110	196	587	41	114	225
SPB 710-10	710.6	717.6	7	4545	110	196	667	41	114	225
SPB 800-10	800.6	807.6	7	4545	110	196	757	41	114	225
SPB 900-10	900.6	907.6	7	5050	125	196	853	34.5	127	245
SPB 1000-10	1000.6	1007.6	7	5050	125	196	954	34.5	127	245
SPB 1250-10	1250.0	1257.0	7	5050	125	196	1203	34.5	127	245

SPC

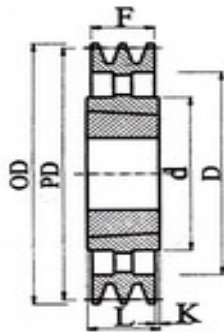

TYPE 8

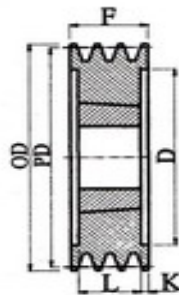

TYPE 3

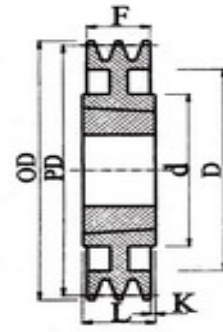

TYPE 6

3 GROOVE										
型号 PART NO.	节径 P.D.	外径 O.D.	图例 TYPE	锥套 BUSH NO.	最大孔径 MAX BORE	F	D	K	L	d
SPC 200-03	200.0	210.0	3	2517	60	85	144	20	45	-
SPC 212-03	212.0	222.0	3	3020	75	85	156	17	51	-
SPC 224-03	224.0	234.0	3	3020	75	85	168	17	51	-
SPC 236-03	236.0	246.0	3	3020	75	85	180	17	51	-
SPC 250-03	250.0	260.0	3	3020	75	85	194	17	51	-
SPC 265-03	265.0	275.0	6	3535	90	85	-	0	89	175
SPC 280-03	280.0	290.0	6	3535	90	85	-	0	89	175
SPC 300-03	300.0	310.0	6	3535	90	85	244	2	89	175
SPC 315-03	315.0	325.0	6	3535	90	85	259	2	89	175
SPC 335-03	335.0	345.0	6	3535	90	85	279	2	89	175
SPC 355-03	355.0	365.0	6	3535	90	85	299	2	89	175
SPC 375-03	375.0	385.0	6	3535	90	85	319	2	89	175
SPC 400-03	400.0	410.0	8	3535	90	85	344	2	89	175
SPC 425-03	425.0	435.0	8	3535	90	85	369	2	89	175
SPC 450-03	450.0	460.0	8	3535	90	85	394	2	89	175
SPC 475-03	475.0	485.0	8	3535	90	85	419	2	89	175
SPC 500-03	500.0	510.0	8	3535	90	85	444	2	89	175
SPC 530-03	530.0	540.0	8	3535	90	85	474	2	89	175
SPC 560-03	560.0	570.0	8	3535	90	85	504	2	89	175
SPC 630-03	630.0	640.0	8	4040	100	85	574	8.5	102	210
SPC 710-03	710.0	720.0	8	4040	100	85	654	8.5	102	215
SPC 800-03	800.0	810.0	8	4545	110	85	744	14.5	114	225
SPC 1000-03	1000.0	1010.0	8	5050	125	85	940	21	127	245
SPC 1250-03	1250.0	1260.0	8	5050	125	85	1190	21	127	245

SPC

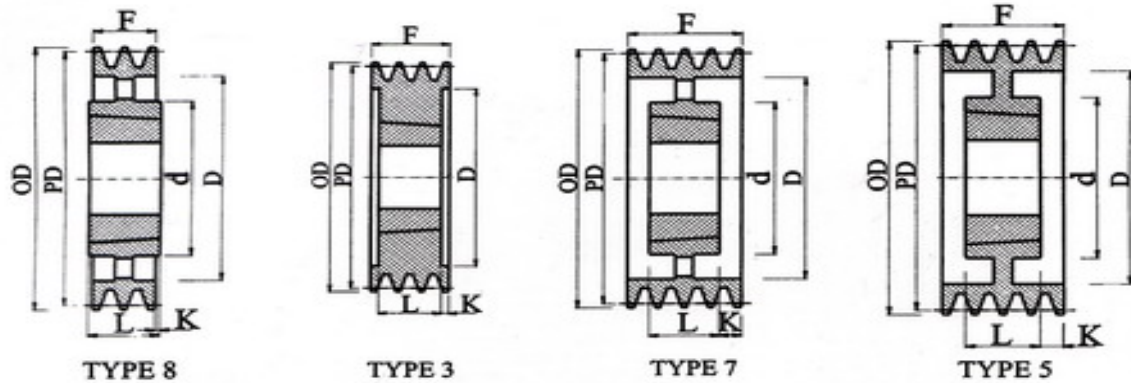

4 GROOVE										
型号*	节径	外径	图例	锥套	最大孔径	F	D	K	L	d
PART NO.	P.D.	O.D.	TYPE	BUSH NO.	MAX BORE					
SPC 200-04	200.0	210.0	3	3020	75	111	144	30	51	-
SPC 212-04	212.0	222.0	3	3020	75	111	156	30	51	-
SPC 224-04	224.0	234.0	3	3535	90	111	168	11	89	-
SPC 236-04	236.0	246.0	3	3535	90	111	180	11	89	-
SPC 250-04	250.0	260.0	3	3535	90	111	194	11	89	-
SPC 265-04	265.0	275.0	3	3535	90	111	209	11	89	-
SPC 280-04	280.0	290.0	5	3535	90	111	224	11	89	175
SPC 300-04	300.0	310.0	5	3535	90	111	244	11	89	175
SPC 315-04	315.0	325.0	5	3535	90	111	259	11	89	175
SPC 335-04	335.0	345.0	5	3535	90	111	279	11	89	175
SPC 355-04	355.0	365.0	5	3535	90	111	299	11	89	175
SPC 375-04	375.0	385.0	5	3535	90	111	319	11	89	175
SPC 400-04	400.0	410.0	7	3535	90	111	344	11	89	175
SPC 425-04	425.0	435.0	7	3535	90	111	369	11	89	175
SPC 450-04	450.0	460.0	7	3535	90	111	394	11	89	175
SPC 475-04	475.0	485.0	7	3535	90	111	419	11	89	175
SPC 500-04	500.0	510.0	7	3535	90	111	444	11	89	175
SPC 530-04	530.0	540.0	7	4040	100	111	474	4.5	102	210
SPC 560-04	560.0	570.0	7	4040	100	111	504	4.5	102	210
SPC 630-04	630.0	640.0	8	4545	110	111	574	-	114	225
SPC 710-04	710.0	720.0	8	4545	110	111	654	-	114	225
SPC 800-04	800.0	810.0	8	5050	125	111	744	8	127	245
SPC 900-04	900.0	910.0	8	5050	125	111	840	8	127	245
SPC 1000-04	1000.0	1010.0	8	5050	125	111	940	8	127	245
SPC 1250-04	1250.0	1260.0	8	5050	125	111	1190	8	127	245

SPC

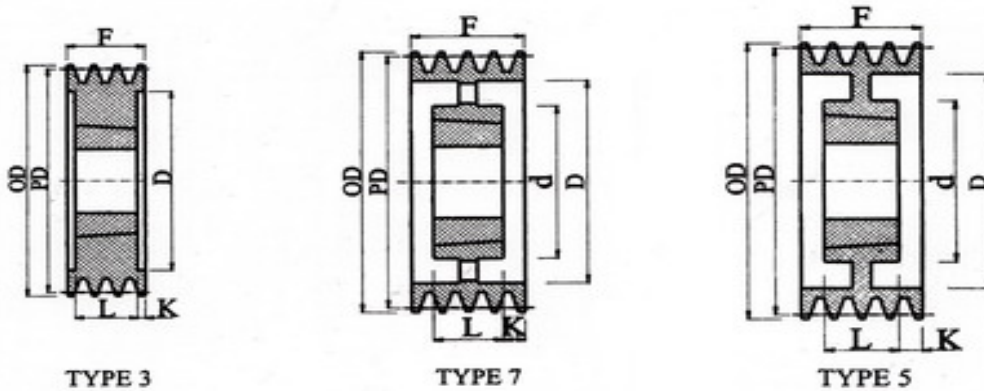

5 GROOVE										
型号 PART NO.	节径 P.D.	外径 O.D.	图例 TYPE	锥套 BUSH NO.	最大孔径 MAX BORE	F	D	K	L	d
SPC 200-05	200.0	210.0	3	3535	90	136	145	23.5	89	-
SPC 212-05	212.0	222.0	3	3535	90	136	156	23.5	89	-
SPC 224-05	224.0	234.0	3	3535	90	136	168	23.5	89	-
SPC 236-05	236.0	246.0	3	3535	90	136	180	23.5	89	-
SPC 250-05	250.0	260.0	3	3535	90	136	194	23.5	89	-
SPC 265-05	265.0	275.0	3	3535	90	136	209	23.5	89	-
SPC 280-05	280.0	290.0	3	3535	90	136	224	23.5	89	-
SPC 300-05	300.0	310.0	5	3535	90	136	244	23.5	89	175
SPC 315-05	315.0	325.0	5	3535	90	136	259	23.5	89	175
SPC 335-05	335.0	345.0	5	3535	90	136	279	23.5	89	175
SPC 355-05	355.0	365.0	5	3535	90	136	299	23.5	89	175
SPC 375-05	375.0	385.0	5	3535	90	136	319	23.5	89	175
SPC 400-05	400.0	410.0	7	3535	90	136	344	23.5	89	175
SPC 425-05	425.0	435.0	7	3535	90	136	369	23.5	89	175
SPC 450-05	450.0	460.0	7	4040	100	136	394	17	102	210
SPC 475-05	475.0	485.0	7	4040	100	136	419	17	102	210
SPC 500-05	500.0	510.0	7	4040	100	136	444	17	102	210
SPC 530-05	530.0	540.0	7	4545	110	136	474	11	114	225
SPC 560-05	560.0	570.0	7	4545	110	136	504	11	114	225
SPC 630-05	630.0	640.0	7	5050	125	136	574	4.5	127	245
SPC 710-05	710.0	720.0	7	5050	125	136	654	4.5	127	245
SPC 800-05	800.0	810.0	7	5050	125	136	744	4.5	127	245
SPC 900-05	900.0	910.0	7	5050	125	136	840	4.5	127	245
SPC 1000-05	1000.0	1010.0	7	5050	125	136	940	4.5	127	245
SPC 1250-05	1250.0	1260.0	7	5050	125	136	1190	4.5	127	245

SPC

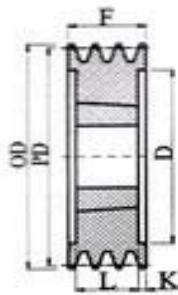

TYPE 3

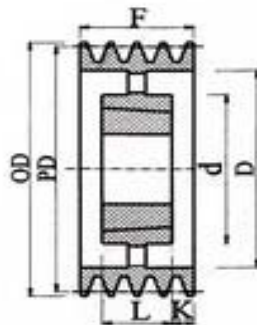

TYPE 7

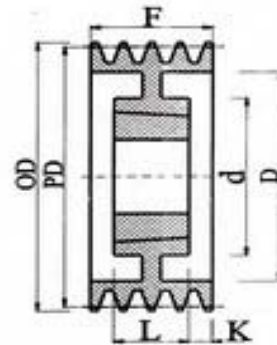

TYPE 5

6 GROOVE										
型号 PART NO.	节径 P.D.	外径 O.D.	图例 TYPE	锥套 BUSH NO.	最大孔径 MAX BORE	F	D	K	L	d
SPC 200-06	200.0	210.0	3	3535	90	162	144	36.5	89	-
SPC 212-06	212.0	222.0	3	3535	90	162	156	36.5	89	-
SPC 224-06	224.0	234.0	3	3535	90	162	168	36.5	89	-
SPC 236-06	236.0	246.0	3	3535	90	162	180	36.5	89	-
SPC 250-06	250.0	260.0	3	3535	90	162	194	36.5	89	-
SPC 265-06	265.0	275.0	3	3535	90	162	209	36.5	89	-
SPC 280-06	280.0	290.0	3	3535	90	162	224	36.5	89	-
SPC 300-06	300.0	310.0	5	3535	90	162	244	36.5	89	175
SPC 315-06	315.0	325.0	5	3535	90	162	259	36.5	89	175
SPC 335-06	335.0	345.0	5	3535	90	162	279	36.5	89	175
SPC 355-06	355.0	365.0	5	3535	90	162	299	36.5	89	175
SPC 375-06	375.0	385.0	5	4040	100	162	319	30	102	210
SPC 400-06	400.0	410.0	7	4040	100	162	344	30	102	210
SPC 425-06	425.0	435.0	7	4040	100	162	369	30	102	210
SPC 450-06	450.0	460.0	7	4545	110	162	394	24	114	240
SPC 475-06	475.0	485.0	7	4545	110	162	419	24	114	240
SPC 500-06	500.0	510.0	7	4545	110	162	444	24	114	240
SPC 530-06	530.0	540.0	7	5050	125	162	474	17.5	127	245
SPC 560-06	560.0	570.0	7	5050	125	162	504	17.5	127	245
SPC 630-06	630.0	640.0	7	5050	125	162	574	17.5	127	245
SPC 710-06	710.0	720.0	7	5050	125	162	654	17.5	127	245
SPC 800-06	800.0	810.0	7	5050	125	162	744	17.5	127	245
SPC 900-06	900.0	910.0	7	5050	125	162	840	17.5	127	245
SPC 1000-06	1000.0	1010.0	7	5050	125	162	940	17.5	127	245
SPC 1250-06	1250.0	1260.0	7	5050	125	162	1190	17.5	127	245

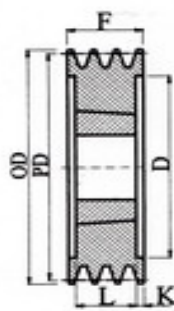

TYPE 3

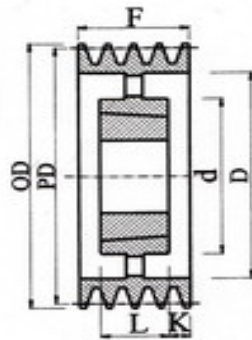

TYPE 7

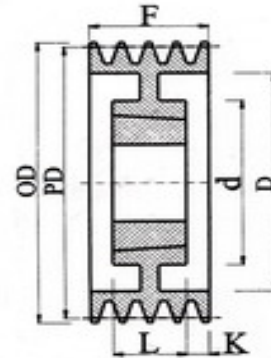

TYPE 5

8 GROOVE										
型号 PART NO.	节径 P.D.	外径 O.D.	图例 TYPE	锥套 BUSH NO.	最大孔径 MAX BORE	F	D	K	L	d
SPC 200-08	200.0	210.0	3	3535	90	213	144	62	89	-
SPC 212-08	212.0	222.0	3	3535	90	213	156	62	89	-
SPC 224-08	224.0	234.0	3	3535	90	213	168	62	89	-
SPC 236-08	236.0	246.0	3	3535	90	213	180	65	89	-
SPC 250-08	250.0	260.0	3	3535	90	213	194	62	89	-
SPC 265-08	265.0	275.0	3	3535	90	213	209	62	89	-
SPC 280-08	280.0	290.0	3	3535	90	213	224	62	89	-
SPC 300-08	300.0	310.0	5	4040	100	213	244	55.5	102	-
SPC 315-08	315.0	325.0	5	4040	100	213	259	55.5	102	-
SPC 335-08	335.0	345.0	5	4040	100	213	279	55.5	102	210
SPC 355-08	355.0	365.0	5	4040	100	213	299	55.5	102	210
SPC 375-08	375.0	385.0	5	4545	110	213	319	49.5	114	240
SPC 400-08	400.0	410.0	7	4545	110	213	344	49.5	114	240
SPC 425-08	425.0	435.0	7	4545	110	213	369	49.5	114	240
SPC 450-08	450.0	460.0	7	5050	125	213	394	43	127	245
SPC 475-08	475.0	485.0	7	5050	125	213	419	43	127	245
SPC 500-08	500.0	510.0	7	5050	125	213	444	43	127	245
SPC 530-08	530.0	540.0	7	5050	125	213	474	43	127	245
SPC 560-08	560.0	570.0	7	5050	125	213	504	43	127	245
SPC 630-08	630.0	640.0	7	5050	125	213	574	43	127	245
SPC 710-08	710.0	720.0	7	5050	125	213	654	43	127	245
SPC 800-08	800.0	810.0	7	5050	125	213	744	43	127	245
SPC 1000-08	1000.0	1010.0	7	5050	125	213	940	43	127	245
SPC 1250-08	1250.0	1260.0	7	5050	125	213	1190	43	127	245

SPC

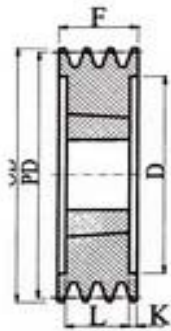

TYPE 3

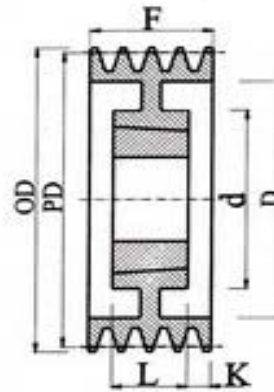

TYPE 5

10 GROOVE										
型号 PART NO.	节径 P.D.	外径 O.D.	图例 TYPE	锥套 BUSH NO.	最大孔径 MAX BORE	F	D	K	L	d
SPC 224-10	224.0	234.0	3	4040	100	264	168	81	102	-
SPC 236-10	236.0	246.0	3	4040	100	264	180	81	102	-
SPC 250-10	250.0	260.0	3	4040	100	264	194	81	102	-
SPC 280-10	280.0	290.0	3	4040	100	264	224	81	102	-
SPC 300-10	300.0	310.0	3	4545	110	264	244	75	114	-
SPC 315-10	315.0	325.0	3	4545	110	264	259	75	114	-
SPC 335-10	335.0	345.0	3	4545	110	264	279	75	114	-
SPC 355-10	355.0	365.0	3	4545	110	264	299	75	114	-
SPC 375-10	375.0	385.0	3	4545	110	264	319	75	114	-
SPC 400-10	400.0	410.0	5	5050	125	264	344	68.5	127	245
SPC 450-10	450.0	460.0	5	5050	125	264	394	68.5	127	245
SPC 500-10	500.0	510.0	5	5050	125	264	444	68.5	127	245
SPC 560-10	560.0	570.0	5	5050	125	264	504	68.5	127	245
SPC 630-10	630.0	640.0	5	5050	125	264	574	68.5	127	245
SPC 710-10	710.0	720.0	5	5050	125	264	654	68.5	127	245
SPC 800-10	800.0	810.0	5	5050	125	264	744	68.5	127	245
SPC 1000-10	1000.0	1010.0	5	5050	125	264	940	68.5	127	245
SPC 1250-10	1250.0	1260.0	5	5050	125	264	1190	68.5	127	245